



**KUKKO**  
Tool factory

A world **in motion**  
since 1919!

Specialized in extractors

world in motion  
ine Welt in Bewegung



2nd edition

**Puller guide –**  
how to choose the right tool





Dear Sir/Madam,

our sector offers with its products an ever-increasing number of tools for carrying out repairs and working in the various sectors of industry, trade and automotive operations.

It is the aim of any trader to guarantee that their customers receive high quality and quick advice at any time. The challenge is to deepen the specialist knowledge needed for sales.

We are happy to help you with this with the new puller basics for the KUKKO brand!

If your customers need a puller, you will usually be faced with the following questions:

- **What principles actually exist for the puller?**
- **Which puller is right for my problem?**
- **How does it work and what do I have to watch out for during use?**
- **Which jaws and spindles are available as an alternative for my KUKKO puller?**

In future, you will be able to answer these questions quickly and easily with the new puller basics. Kukki will reliably guide you through the 4 principles of the puller and provide you with information using product videos, photos, videos and tables.

Thank you for your interest in KUKKO products and enjoy reading and discovering.

Your KUKKO Team!



Usage video for  
**Outside-pulling**



Usage video for  
the internal pulling



Usage video for  
the separating



Usage video for  
the ball bearing removal and  
installation



KUKKO on Facebook  
[www.facebook.com/kukkotools](http://www.facebook.com/kukkotools)



The 4 puller principles at a glance	page 4 - 5	GENERAL
Overview: of all series	page 6 - 7	
General overview of the KUKKO line	page 40 - 41	
KUKKO-Technologies	page 42	
Precautionary Notes and Helpful Hints	page 43	

<b>EXTERNAL-pulling</b>	page 8 - 23	EXTERNAL
Selection of the right external puller	page 8 - 9	
Special features of series 20 and 30	page 10 - 11	
Overview: Puller Jaws	page 12 - 17	
Overview : Spindles	page 18 - 23	

<b>INTERNAL-pulling</b>	page 24 - 27	INTERNAL
Selection of the right internal puller device	page 24	
Special features of series 21 and 22	page 25	
Overview: Internal pulling with counter stay	page 26 - 27	
Overview: Internal pulling with slide hammer	page 26 - 27	

<b>SEPARATING</b>	page 28 - 29	SEPARATING
Selection of the right separating device	page 28	
Special features of series 15, 17 and 18	page 29	

<b>BALL BEARING removal and installation</b>	page 30 - 31	BALL BEARING
Selection of the right bearing puller	page 30	
Overview: Ball bearing removal and installation	page 31	

<b>Series 800</b>	page 32 - 35	SERIES 800
Selection of the right puller	page 24	
Possible combinations of the modular system 800	page 25	

<b>BALL JOINT extracting</b>	Seite 36 - 37	BALL JOINT
Selection of the right ball joint extractors	Seite 36	
Overview: ball joint extractors	Seite 37	

## EXTERNAL



The part to be removed is on a shaft and is freely accessible from the outside!

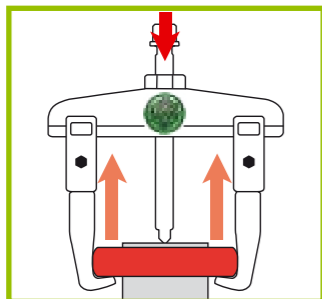
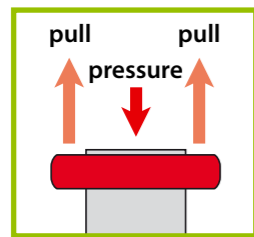

For more informations see pages: 6-7; 8-23

## INTERNAL



The part to be removed is in a recess!

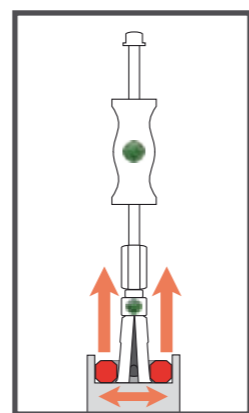
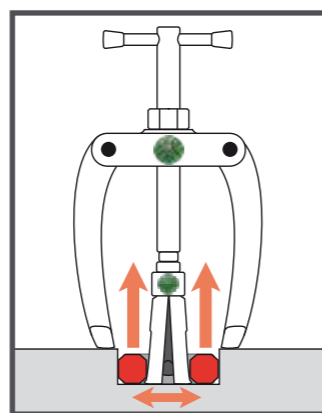
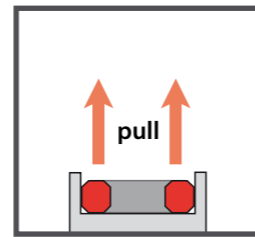
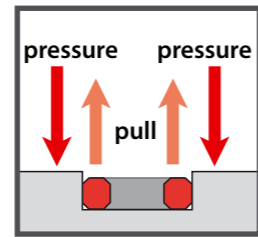

For more informations see pages: 6-7; 24-27

## SEPARATING



The part to be removed is level. It is not possible to use standard puller jaws!

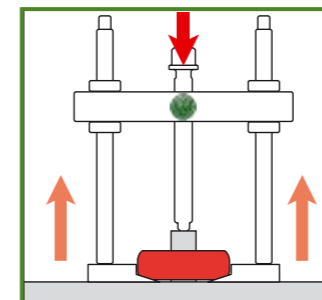
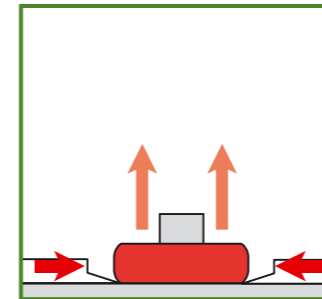
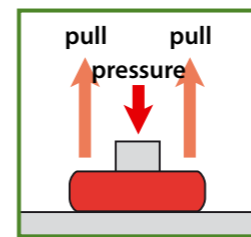

For more informations see pages: 6-7; 28-29

## BALL BEARING



Non-contact extraction!

A The ball bearing is in a housing and on a shaft at the same time.

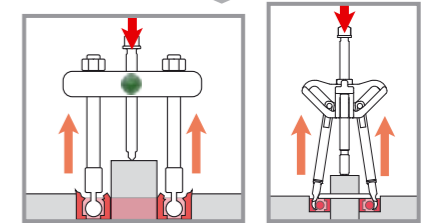
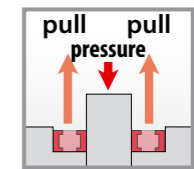

B The ball bearing is inside a casing, but has no shaft for support.

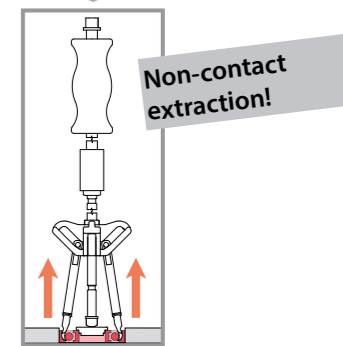
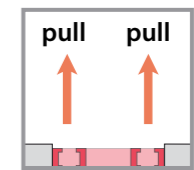

Non-contact extraction!

For more informations see pages: 6-7; 30-31



GENERAL

series									mini bearings micro mechanical work	small bearings precision mechanical work	medium bearings mechanical work	large bearings heavy mechanical work	ball bearings	ALL bearing types	EXTERNAL	INTERNAL		SEPARATING	BALL BEARING removal	
	mm	mm	mm	mm	mm	mm	mm	mm								mm	mm		mm	mm
20-AV / 11	375-650	200-700	✓	✓	✓	✓	✓	-	-	-	-	✓	✓	✓	✓	-	✓	-	-	-
12	100-650	100-350	-	✓	✓	-	✓	-	-	-	✓	✓	✓	✓	✓	-	-	-	-	-
13	130-280	250	-	✓	✓	✓	✓	-	-	-	✓	-	✓	✓	✓	-	-	✓	-	-
14	6-140	85-160	-	✓	-	✓	-	-	-	✓	-	-	✓	✓	✓	-	-	-	-	-
20 / 30	90-750	100-700	✓	✓	✓	✓	✓	-	-	-	✓	✓	✓	✓	✓	-	✓	-	-	-
28	50-250	100-250	-	✓	-	✓	-	-	-	✓	✓	-	✓	✓	✓	-	-	-	-	-
41 / 42	60-180	40-200	-	✓	✓	✓	✓	-	-	-	✓	-	✓	✓	✓	-	-	-	-	-
43	60-80	50-80	-	✓	-	✓	✓	-	-	-	✓	-	✓	✓	✓	-	-	-	-	-
44 / 45	100-600	100-350	-	✓	-	✓	✓	-	-	-	✓	-	✓	✓	✓	-	-	-	-	-
46 / 47	300-500	300-450	-	✓	✓	✓	✓	✓	-	-	✓	-	✓	✓	✓	-	-	-	-	-
48	60	40	-	✓	-	✓	-	-	-	✓	-	-	✓	✓	✓	-	-	-	-	-
110	50-350	50-250	✓	✓	-	✓	-	-	-	✓	✓	-	✓	✓	✓	-	✓	-	-	-
112 / 113	55-185	45-165	-	✓	-	✓	✓	-	-	-	✓	-	✓	✓	✓	-	-	-	-	-
120 / 130	100-350	100-200	✓	✓	-	✓	✓	-	-	-	✓	-	✓	✓	✓	-	✓	-	-	-
140 / Micro	2,25-5,25	10-20	-	✓	-	✓	-	-	✓	-	-	-	✓	✓	✓	-	-	-	-	-
200	250	80-180	✓	✓	-	✓	-	-	-	-	✓	-	✓	✓	✓	-	✓	-	-	-
201 / 202	100-380	75-300	-	✓	-	✓	✓	-	-	-	✓	-	✓	✓	✓	-	-	-	-	-
203	120-400	75-300	-	✓	-	✓	✓	-	-	-	✓	-	✓	✓	✓	-	-	-	-	-
204 / 210	50-150	70-325	-	✓	-	✓	-	-	-	✓	✓	-	✓	✓	✓	-	-	✓	-	-
205 / 207	100-550	100-540	-	✓	✓	✓	✓	-	-	-	✓	-	✓	✓	✓	-	-	-	-	-
206	100-500	100-540	-	✓	✓	✓	✓	-	-	-	✓	-	✓	✓	✓	-	-	-	-	-
208 / 209	20-230	95-190	-	✓	-	✓	✓	-	-	-	✓	-	✓	✓	✓	-	-	-	-	-
208-0 / 209-0	100	50-100	-	✓	-	✓	✓	-	-	-	✓	-	✓	✓	✓	-	-	-	-	-
482 / 483	15-250	40-250	-	✓	-	✓	✓	-	-	-	✓	-	✓	✓	✓	-	-	-	-	-
486	22-160	55-180	✓	✓	-	✓	✓	✓	-	-	✓	-	✓	✓	✓	-	✓	-	-	-
21	∅ 5-200	-	-	✓	-	-	-	-	-	✓	✓	-	✓	✓	-	✓	✓	-	-	-
22-0	-	-	-	✓	-	-	-	-	-	✓	✓	-	✓	✓	-	✓	✓	-	-	-
22	55-300	120-260	-	✓	-	✓	-	-	-	✓	✓	-	✓	✓	-	✓	-	-	-	-
16	∅ 60-155	-	-	✓	-	-	-	-	-	-	✓	-	✓	✓	-	✓	✓	-	-	-
15	∅ 6-250	-	-	✓	-	-	-	-	-	✓	✓	-	✓	✓	-	-	-	✓	-	-
17	∅ 8-155	-	-	✓	-	-	-	-	-	✓	✓	-	✓	✓	-	-	-	✓	-	-
18	25-440	60-400	-	✓	✓	✓	-	-	-	-	✓	-	✓	✓	-	-	-	✓	-	-
69	-	-	-	✓	-	✓	-	-	-	-	✓	✓	-	-	-	-	-	-	✓	-
70	-	-	-	✓	-	-	-	-	-	✓	✓	✓	✓	-	-	-	-	-	✓	✓

GENERAL

## Selection of the right external puller



### 1st step: Measuring the space available

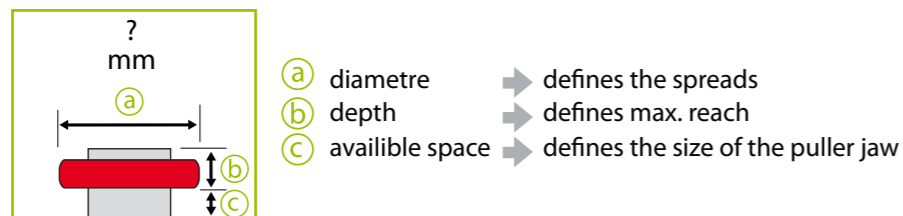

### 2nd step: Selection of the puller type

**Requirement:**

- The puller is used for various applications.
- The puller must be able to change characteristics e.g. increase the reach etc.

Recommendation of KUKKO

**Sliding-arm pullers with constantly parallel jaws**

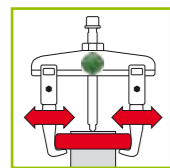

The puller jaws can be moved continuously (even asymmetrically) on the cross-beam, and can be fixed to the cross-beam using a bolt connection or knurled knob.

Series available

11 ; 20; 20+; 20-S; 20+S; 20-S-T; 20-S+T; 30; 30+; 30-S; 30+S; 30-S-T; 30-S+T; 110; 120; 130

**Requirement:**

- The same removal application is always used.

Recommendation of KUKKO

**Puller with self-centering puller jaws (autogrip)**

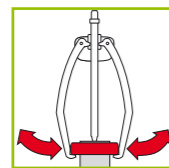

The two puller jaws are connected to each other. The pullers therefore ensure automatic self-tensioning and self-centering of the jaws.

Series available

43; 44; 45; 482; 483; 486; 844; 845

**Requirement:**

- The same removal application is always used.
- Same application at different depths.

Recommendation of KUKKO

**Puller with swivel puller jaws**

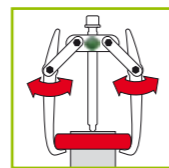

The jaws and the cross-beam are connected by movable brackets. As the spindle pulls, the jaws tense and tighten firmly. An additional option is swivel-jaws pullers. Reversing the puller jaws expands or reduces the reach.

Series available

41; 42; 46; 47; 201; 203; 205; 206; 207; 208; 209

**Requirement:**

- The bearing is flush.
- It is especially important that the puller arms do not slip off.

Recommendation of KUKKO

**Puller with side tension clamps.**

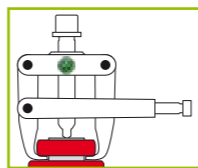

To remove flush parts the puller jaws grab beneath the part to be removed when pulling on the side clamps and loosen the part even before the actual pulling process. The clamp presses the puller jaws securely onto the part to be removed. This ensures that the puller jaws do not slip off.

Series available

204; 210

### 3rd step: How much force is required?

A normal amount of pressure is required.

High pressure is required because the part to be removed is particularly secure, or rusted.

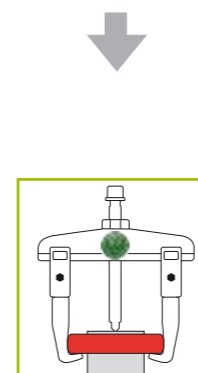

**Puller with mechanical pressure spindle**

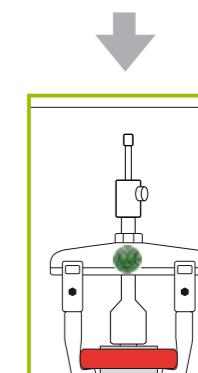

**Puller with long hydraulic spindle**

### 4th step: Select model

The selected pulling tool normally states the necessary power and pulling force. However, in order to be absolutely sure, you should always choose the largest possible model for dimension ranges which cross over.

Detailed dimension and performance details for all models can be found at [www.KUKKO.com](http://www.KUKKO.com)

#### For example:

diametre: 142 mm / 120 mm / 135 mm  
 depth: 135 mm / 120 mm / 220 mm  
 available space: unlimited

Specification: There must be pulled various bearings at different depths.  
 Target: We are looking for a puller which can be individually adapted.  
**KUKKO recommended to use pullers with sliding puller arms that are always parallel.**

The bearings are on the shaft.  
**KUKKO recommended to use a puller with a mechanical spindle.**

**According to the KUKKO website choose the pullers from series 20 and 30 in size 2.**

The decision falls to : 30-2+ and 2-V-150-S

Advantage:

- with the 3-jaw model, you have the best possible load distribution and a particularly secure hold.
- You can adjust your puller to the relevant reach by buying the extensions.
- The quick adjusting capability allows the reach to be changed quickly.



EXTERNAL

EXTERNAL

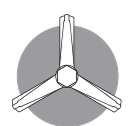

You should always give a 3-jaw puller preference if the access conditions permit. The uniform load distribution guarantees a particularly secure hold on the to be extracted part.

### How it works

#### STANDARD

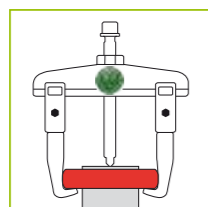

External pulling is the most common type of pulling. The part to be extracted such as a gear wheel, pulley or ball bearing, is gripped from the outside. The part is loosened from the shaft by the pull of the pressure screw.

#### as INTERNAL extractor

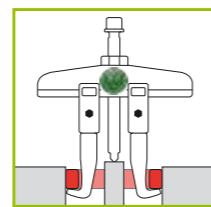

The external pullers can also be used as internal extractors by turning the jaws. *Important: When used as internal extractors, a fixed center point is required to brace the pressure screw of the products in these series.*

### Accessories: Modular extensions

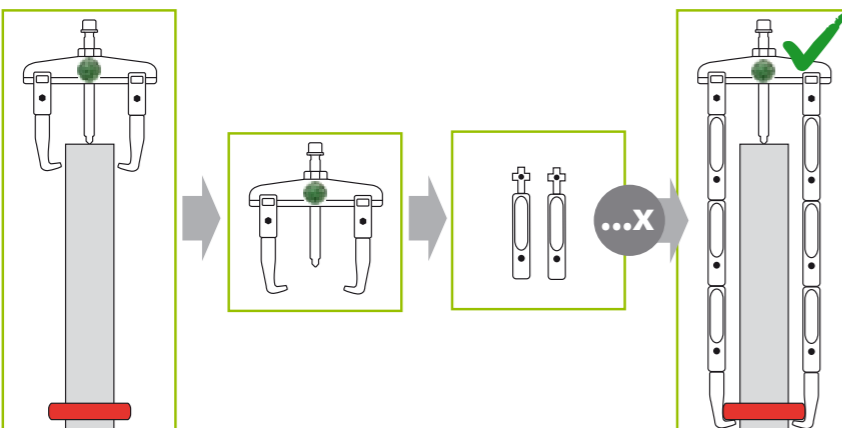

For the 20 and 30 series, we offer modular extensions (combinable with size 1-20). If the part to be removed sits deep inside a shaft, jaw extensions will be needed.

### Accessories: Side clamp

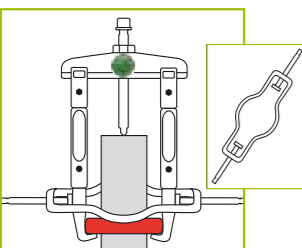

The side clamp is available separately (No. 219-1). It is attached to the puller jaw after the puller has been fitted and prevents slippage of the puller jaw under very high forces.

### Accessories: Grease hydraulic pressure spindle

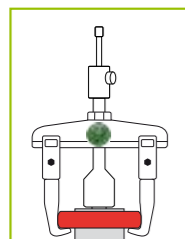

The hydraulic spindle ensures controlled and secure operating of 7-20 t. It uses the entire capability of the puller, over and above what can be achieved with a mechanical spindle. When replacing a mechanical spindle with a hydraulic one, there is also a considerable reduction in the drive force which needs to be used. **See also pages: 18, 22, 23**

### Accessories: auxiliary grease hydraulic rams

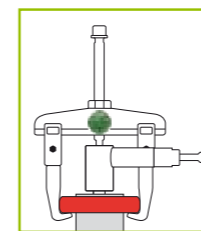

**For use with mechanical KUKKO pullers from size 3.**

The auxiliary grease hydraulic rams are a good tool for significantly increasing the pressure when removing very secure parts. The hydraulic rams are simply secured between the spindle and shaft with the mechanical spindle.

**No conversion of the puller is needed!**

See also page: 18

### Accessories: Puller jaws

**Pullers in series 20 and 30 can easily be adjusted using different puller jaws lengths and types.**



#### Which puller jaws are right for which puller?

The puller jaws that start with **1-** → fit all pullers of size **-1** and **-10**

The puller jaws that start with **2-** → fit all pullers of size **-2** and **-20**

The puller jaws that start with **3-** → fit all pullers of size **-3** and **-30**

The puller jaws that start with **3-** → can also use by the pullers of size **-4** and **-40**

#### Example:

**20-2** → has the puller jaws 2-150-P

→ can also use : 2-151-P; 2-152-P; 2-153-P

→ can also use long puller jaws such as: 2-300-P; 2-301-P; 2-302-P; 2-303-P

### Safety instructions

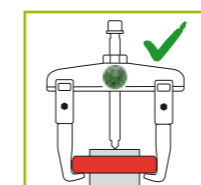

The puller must be centrally positioned for center shafts. If the shaft is not centered, pulling with parallel jaws may result asymmetrical pulling.

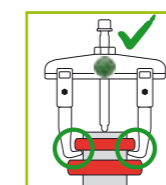
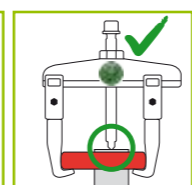

If there are several parts to be pulled, always remove them one-by-one. Never remove several parts simultaneously.

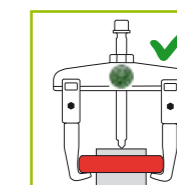
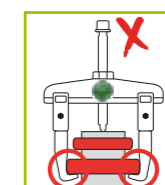

Jaws must always be positioned directly below the part to be removed.

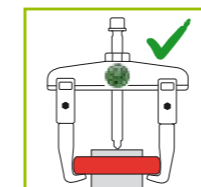
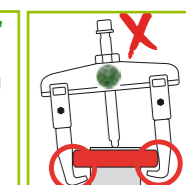

The jaws of the leg must be set firmly and completely against the cross-beam

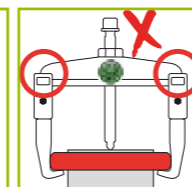

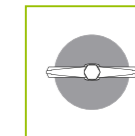

If there is adequate free space around the part, we recommend a 3-jaw puller for optimal force distribution.



A 2-jaw puller is always used in situations where there is insufficient space for a 3-jaw puller.

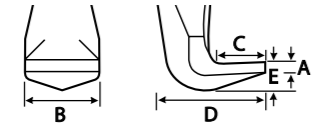
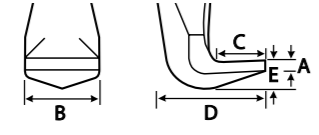
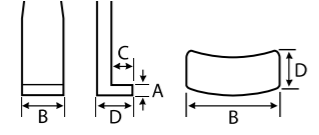
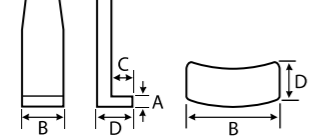
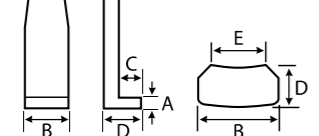
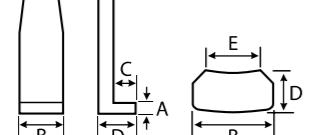

  Pulling jaws for 2-jaw pullers, series 20 and 30

Series	Dimensions of the puller jaws	A mm	B mm	C mm	D mm	E mm	 mm	Art.-No. pair	QUICK adjust TECHNOLOGY 品番 pair	suitable for  KUKKO-pullers:	Art.-No. set	QUICK adjust TECHNOLOGY 品番 set	suitable for  KUKKO-pullers:
									Art.-No. pair	Art.-No. set		Art.-No. set	Art.-No. set
20 20+ 30 30+		3,0	20	15	31	10	100	1-90-P	1-92-P	20-1; 20-10	1-90-S	1-92-S	30-1; 30-10
		4,0	24	18	40	9	150	2-150-P	2-152-P	20-2; 20-20	2-150-S	2-152-S	30-2; 30-20
		4,0	35	37	67	20	200	3-200-P	3-202-P	20-3; 20-30; 20-4; 20-40	3-200-S	3-202-S	30-3; 30-30; 30-4; 30-40
20 20+ 30 30+		3,0	20	15	31	10	200	1-190-P	1-192-P	20-1; 20-10	1-190-S	1-192-S	30-1; 30-10
		3,0	20	15	31	10	250	1-250-P	1-252-P	20-1; 20-10	1-250-S	1-252-S	30-1; 30-10
		4,0	24	18	40	9	300	2-300-P	2-302-P	20-2; 20-20	2-300-S	2-302-S	30-2; 30-20
		4,0	35	37	67	20	300	3-300-P	3-302-P	20-3; 20-30; 20-4; 20-40	3-300-S	3-302-S	30-3; 30-30; 30-4; 30-40
		4,0	35	37	67	20	400	3-400-P	3-402-P	20-3; 20-30; 20-4; 20-40	3-400-S	3-402-S	30-3; 30-30; 30-4; 30-40
		4,0	35	37	67	20	500	3-500-P	3-502-P	20-3; 20-30; 20-4; 20-40	3-500-S	3-502-S	30-3; 30-30; 30-4; 30-40
20-S 20+S 30-S 30+S		2,6	30	7	14	-	100	1-91-P	1-93-P	20-1; 20-10	1-91-S	1-93-S	30-1; 30-10
		4,0	32	8	19	-	150	2-151-P	2-153-P	20-2; 20-20	2-151-S	2-153-S	30-2; 30-20
		6,5	35	17	52	-	200	3-201-P	3-203-P	20-3; 20-30	3-201-S	3-203-S	30-3; 30-30
20-S 20+S 30-S 30+S		2,6	30	7	14	-	200	1-191-P	1-193-P	20-1; 20-10	1-191-S	1-193-S	30-1; 30-10
		2,6	30	7	14	-	250	1-251-P	1-253-P	20-1; 20-10	1-251-S	1-253-S	30-1; 30-10
		4,0	32	8	19	-	300	2-301-P	2-303-P	20-2; 20-20	2-301-S	2-303-S	30-2; 30-20
		6,5	35	17	40	-	300	3-301-P	3-303-P	20-3; 20-30	3-301-S	3-303-S	30-3; 30-30
		6,5	35	17	40	-	400	3-401-P	3-403-P	20-3; 20-30	3-401-S	3-403-S	30-3; 30-30
		6,5	35	17	40	-	500	3-501-P	3-503-P	20-3; 20-30	3-501-S	3-503-S	30-3; 30-30
20-S-T 20+S-T 30-S-T 30+S-T		3,0	24	7	12	15	100	1-94-P	1-95-P	20-1; 20-10	1-94-S	1-95-S	30-1; 30-10
20-S-T 20+S-T 30-S-T 30+S-T		3,0	24	7	12	15	200	1-194-P	1-195-P	20-1; 20-10	1-194-S	1-195-S	30-1; 30-10
		3,0	24	7	12	15	250	1-254-P	1-255-P	20-1; 20-10	1-254-S	1-255-S	30-1; 30-10



Pulling jaws

Series	Dimensions of the puller jaws	A mm	B mm	C mm	D mm	E mm	C2 mm	E2 mm	Art.-No. pair	suitable for KUKKO-pullers:	Art.-No. set	suitable for KUKKO-pullers:
12-1 - 12-3		3,0	14	13	25	17	-	-	-	-	12-1-100-S	12-1
		3,0	17	13	27	20	-	-	-	-	12-2-125-S	12-2
		4,0	20	15	35	28	-	-	-	-	12-3-180-S	12-3
12-4 - 12-7		4	18	19	63	20	21	30	-	-	12-4-225-E	12-4
		4	18	19	63	20	21	30	-	-	12-5-275-E	12-5
		4	28	22	70	20	21	30	-	-	12-6-300-E	12-6
		4	28	22	70	20	21	30	-	-	12-7-350-E	12-7
14		2,5	21	3,5	8,5	-	-	-	14-1-85-P	14-1	-	-
		4,0	30	4	1-2	-	-	-	14-2-125-P	14-2	-	-
		4,0	30	5	1-3	-	-	-	14-3-160-P	14-3	-	-
		2,5	11	3,5	8,5	-	-	-	14-01-85-P	14-01	-	-
		4,0	30	5	1-3	-	-	-	14-03-160-P	14-03	-	-
41 42		2,0	10	7	15	4	-	-	41-0-40-P	41-0	42-0-40-S	42-0
		2,0	11	8	15	4	-	-	41-1-65-P	41-1	42-1-65-S	42-1
		2,0	11	9	16	5	-	-	41-2-80-P	41-2	42-2-80-S	42-2
		3,0	18	13	22	7,5	-	-	41-3-120-P	41-3	42-3-120-S	42-3
		4,0	24	18	35	9	-	-	41-4-160-P	41-4	42-4-160-S	42-4
		5,0	34	23	35	15	-	-	41-5-200-P	41-5	42-5-200-S	42-5
43 44 45		2,0	11	10	17	5	-	-	43-1-50-P	43-1	43-11-50-S	43-11
		2,0	11	10	17	5	-	-	43-2-70-P	43-2	43-12-70-S	43-12
		2,0	11	11	18,5	5	-	-	43-3-80-P	43-3	43-13-80-S	43-13
		3,0	16	11	20	7	-	-	44-1-100-P	44-1	45-1-100-S	45-1
		3,0	17	14	30	10	-	-	44-2-120-P	44-2	45-2-120-S	45-2
		3,0	20	19	32	12	-	-	44-3-160-P	44-3	45-3-160-S	45-3
		3,0	26	22	17	12	-	-	44-4-200-P	44-4	45-4-200-S	45-4
		4,0	28	24	40	16	-	-	44-5-250-P	44-5	45-5-250-S	45-5
		4,0	28	24	40	16	-	-	44-6-275-P	44-6	45-6-275-S	46-6
		7,0	10	22	60	22	-	-	-	-	45-7-350-S	45-7
46 47		8,0	30	22	50	22	-	-	46-300	46-1-A; 46-1-B 46-2-A; 46-2-B	46-300	47-1-A; 47-1-B 47-2-A; 47-2-B
		6,0	30	24	50	22	-	-	46-450	46-2-A; 46-2-B	46-450	47-2-A; 47-2-B
110		2,5	12	5	15	7	-	-	110-01-50-P	110-01; 110-02	-	-
		5	15	10	25	13	-	-	110-1-100-P	110-1; 110-10	-	-
		6	18	12	30	14	-	-	110-2-150-P	110-2; 110-20	-	-
		9	20	12	35	18	-	-	110-3-200-P	110-3	-	-
		9	20	12	35	18	-	-	110-4-250-P	110-4	-	-
112 113		10°	10	7	12	5	-	-	112-1-45-P	112-1	-	-
		15°	10	7	12	5	-	-	112-10-70-P	112-10	-	-
		15°	15	8	15	6	-	-	112-2-70-P	112-2	-	-
		15°	15	8	15	5,5	-	-	112-20-100-P	112-20	113-20-100-S	113-20
		5°	20	11	20	6,5	-	-	112-3-165-P	112-3	113-3-165-S	113-3
120 130		4	21	15	32	9	-	-	0-100-P	120-1; 120-10	0-100-S	130-10
		4	21	15	32	9	-	-	0-148-P	120-2	0-148-S	130-2
		4	28	18	43	15	-	-	0-150-P	120-20	0-150-S	130-20
		4	28	18	43	15	-	-	0-200-P	120-3; 120-30	0-200-S	130-3

EXTERNAL

EXTERNAL





Pulling jaws

Series	Dimensions of the puller jaws	A mm	B mm	C mm	D mm	E mm	A2 mm	B2 mm	C2 mm	D2 mm	E2 mm		Art.-No. pair	suitable for  KUKKO-pullers:	Art.-No. set	suitable for  KUKKO-pullers:	suitable for  KUKKO-pullers:		
<b>201</b> <b>202</b> <b>203</b> <b>208-0</b>		3,0	11	8	17	6	2	11	5	14	6	-		<b>201-075-P</b>	201-0	<b>202-075-S</b>	202-0	203-0	
		3,0	15	12	25	7	2	9	9	22,5	7	-		<b>201-1-85-P</b>	201-1	<b>202-1-85-S</b>	202-1	203-1	
		4,0	26	20	35	7	3	20	18	33	7	8		<b>201-2-130-P</b>	201-2	<b>202-2-130-S</b>	202-2	203-2	
		5,0	26	20	35	12	4	26	20	35	12	8		<b>201-3-260-P</b>	201-3	<b>202-3-260-S</b>	202-3	203-3	
		8,0	26	21	45	20	8	26	17	40	20	-		<b>201-4-300-P</b>	201-4	<b>202-4-300-S</b>	202-4	203-4	
		7,5	8,5	3,5	11,5	7,5	6	6	3,5	8,5	6	-		<b>201-S-P</b>	201-S	<b>202-S-S</b>	202-S	-	
5,0	10	9	15	5	5	10	9	20	5	-		<b>208-0-100-P</b>	208-0	<b>209-0-100-S</b>	209-0	-			
<b>208</b> <b>209</b>		3,5	16	13	26	10	-	-	-	-	-		<b>208-01-125-P</b>	208-01	<b>209-01-125-S</b>	209-01	-		
		4,5	20	20	30	13	-	-	-	-	-	-		<b>208-02-190-P</b>	208-02	<b>209-02-190-S</b>	209-02	-	
<b>204</b>		4,0	22	12	22	8,5	-	-	-	-	-	-		<b>204-1-90-P</b>	204-1	-	-	-	
		3,5	24	12	25	10	-	-	-	-	-	-	-		<b>204-2-100-P</b>	204-2	-	-	-
		4,0	30	21	35	15	-	-	-	-	-	-	-		<b>204-3-140-P</b>	204-3	-	-	-
<b>204-0</b>		2,5	18	10	20	5	-	-	-	-	-	-		<b>204-0-70-P</b>	204-0	-	-	-	
		3,0	24	9	20	6	-	-	-	-	-	-	-		<b>204-02-100-P</b>	204-02 204-V	-	-	-
<b>210</b>		4,0	25	15	35	11	2	25	5	25	17	-		<b>210-1-170-P</b>	210-1	-	-	-	
		4,0	25	15	40	15	1,5	25	5	36	22	-		<b>210-2-270-P</b>	210-2	-	-	-	
		4,0	25	15	50	15	2,0	25	5	31	22	-		<b>210-3-325-P</b>	210-3	-	-	-	
<b>205</b> <b>206</b> <b>207</b>		2,0	14	12	27	7,5	-	-	-	-	-	-		<b>205-00-100-P</b>	205-00	<b>206-00-100-S</b>	206-00	207-00	
		3,0	18	14	41	8	-	-	-	-	-	-	-		<b>205-01-150-P</b>	205-01	<b>206-01-150-S</b>	206-01	207-01
		4,0	24	15	50	18	-	-	-	-	-	-	-		<b>205-02-220-P</b>	205-02	<b>206-02-220-S</b>	206-02; 206-02-B	207-02; 207-02-B
		5,0	30	19	48	18	-	-	-	-	-	-	-		<b>205-1-280-P</b>	205-1	<b>206-1-280-S</b>	206-1; 206-1-B	207-1; 207-1-B
		8,0	30	22	46	20	-	-	-	-	-	-	-		<b>205-2-400-P</b>	205-2	<b>206-2-400-S</b>	206-2; 206-2-B; 209-2-B	207-2; 207-2-B
		4,5	30	22	58	19	-	-	-	-	-	-	-		<b>205-3-540-P</b>	205-3	<b>206-3-540-S</b>	206-3; 206-3-B	207-3; 207-3-B
<b>482</b> <b>483</b>		2,0	8	8	11	4	-	-	-	-	-	-		<b>482-1-40-P</b>	482-1	-	-	-	
		2,5	8	8	12	5	-	-	-	-	-	-		<b>482-2-90-P</b>	482-2	<b>483-2-90-S</b>	483-2	-	
		3,0	14	8	17	8	-	-	-	-	-	-		<b>482-3-150-P</b>	482-3	<b>483-3-150-S</b>	483-3	-	
		3,5	16	9	22	9	-	-	-	-	-	-		<b>482-4-200-P</b>	482-4	<b>483-4-200-S</b>	483-4	-	
		3,5	16	12	25	10	-	-	-	-	-	-		<b>482-5-250-P</b>	482-5	<b>483-5-250-S</b>	483-5	-	
<b>820</b> <b>844</b> <b>845</b>		5,0	30	20	40	8	-	-	-	-	-	-		<b>820-225-P</b>	820-0	-	-	-	
		6,5	25,5	13	40	-	-	-	-	-	-	-		<b>844-100</b>	844-1-B	<b>844-100</b>	845-1-B	-	
		6,5	25,5	13	38	-	-	-	-	-	-	-		<b>844-150</b>	844-2-B	<b>844-150</b>	845-2-B	-	
		6,5	25,5	16	44	-	-	-	-	-	-	-		<b>844-200</b>	844-4-B	<b>844-200</b>	845-4-B	-	
		6,5	25,5	13	42	-	-	-	-	-	-	-		<b>844-250</b>	844-3-B	<b>844-250</b>	845-3-B	-	
		6,5	25,5	13	44	-	-	-	-	-	-	-		<b>844-251</b>	844-5-B	<b>844-251</b>	845-5-B	-	
<b>Y-205</b> <b>Y-206</b>		5,0	29	25	102	33	-	-	-	-	-	-		<b>Y205-00</b>	Y20-205; Y28-205	<b>Y205-00</b>	Y20-206; Y28-206	-	
		5,0	38,5	30	125	41	-	-	-	-	-	-		<b>Y305-00</b>	Y30-205; Y38-205	<b>Y305-00</b>	Y30-206; Y38-206	-	
		10,0	30	42	155	63	-	-	-	-	-	-		<b>Y505-00</b>	Y50-205; Y58-205	<b>Y505-00</b>	Y50-206; Y58-206	-	
<b>Y-208</b>		4,0	24	15	50	18	-	-	-	-	-	-		-	-	<b>206-02-220-S</b>	Y05-208; Y08-208	-	
		4,5	30	22	58	19	-	-	-	-	-	-		-	-	<b>206-3-540-S</b>	Y10-208; Y18-208	-	



**Mechanical pressure spindle**  
For use with KUKKO pullers of all sizes



- KUKKO pressure spindles with milled thread have been specifically engineered for use in KUKKO pullers.
- The pressure spindles are specially coated and therefore guarantee particularly good sliding properties in the thread.
- Optimal adjustment of the spindle to the shaft with 2-sided spindle top.
- The mounted, freely-rotating centering point protects the shaft against damage when applying the pulling force.
- The spindle heads have a band which prevents the wrench from slipping during the pulling process.
- The spindle head and the spindle band (see diagram below) are lasered with the item number.



**Long hydraulic spindle**  
For use with large KUKKO pullers



- Due to their high pressure performance, the hydraulic spindles ensure very secure parts can be removed quickly and effortlessly.
- The hydraulic spindle ensures controlled and safe working.
- It uses the entire capability of the puller, over and above what can be achieved with a mechanical spindle.
- The application of hydraulic pulling force must always be controlled by the use of a torque wrench.



**Auxiliary hydraulic ram**  
For use with mechanical KUKKO pullers from size 3



- The hydraulic rams are a good tool for significantly increasing the pressure when pulling particularly secure parts.
- The hydraulic rams are secured between the spindle and the shaft using the mechanical spindle.
- No conversion of the puller is required!

Care of the puller spindle

**Puller spindle maintenance**

The spindle must always be kept well lubricated. We recommend the use of KUKKO special sliding grease for pressure spindle (Art. No.: 699915), or KUKKO Bio Multi Oil (Art. No.: 699990). A tube of KUKKO special sliding grease for pressure spindle is free with every order of an original KUKKO puller.



Selection of the right spindle top.

Optimal adjustment of the spindle to the shaft with 2-sided spindle tip (ball and tip).



Optimal complement for KUKKO pressure screws

Set of interchangeable pressure pads for KUKKO pressure screws „6 in 1“

With 6 different application options for individual adaptation to the shaft.

Use: for different shaft forms



Use: for hollow shafts



Mechanical pressure spindles from KUKKO only complete with a safety-first label.

Hang the safety-first label back on the spindle after use of the puller.



Precautionary Notes and Helpful Hints



Always wear suitable personal protective equipment, including protective goggles.



Never use an electric- or pneumatic-powered impact/hammer drill for driving a pulling tool.

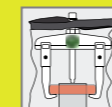

Always wrap the pulling tool and the workpiece in a protective blanket as a precaution against the potential effects of sudden release.



Keep the threads of all pressure spindle and cross-beam clean and well oiled.



## Backfitting 2- and 3-jaw pullers from mechanic up to hydraulic spindle



When using pullers with hydraulic spindles, the application of hydraulic pulling force must always be controlled, i.e., by the use of a torque wrench.

品番	+	最大		最大 Nm	
		t	kN	最大 Nm	最大 Nm
20-2+	8-01	7	70	150	12
20-20	8-01	7	70	150	12
20-20+	8-01	7	70	150	12
20-2-3	8-01	7	70	150	12
20-20-3	8-01	7	70	150	12
20-3	8-02	8,5	85	300	14
20-3+	8-02	8,5	85	300	14
20-30	8-02	8,5	85	300	14
20-30+	8-02	8,5	85	300	14
20-3-3	8-02	8,5	85	300	14
20-3-4	8-02	8,5	85	300	14
20-3-5	8-02	8,5	85	300	14
20-30-3	8-02	8,5	85	300	14
20-30-4	8-02	8,5	85	300	14
20-30-5	8-02	8,5	85	300	14
20-4	8-1-B	15	150	400	45
20-4-3	8-1-B	15	150	400	45
20-4-5	8-1-F	15	150	400	45
20-40	8-1-B	15	150	400	45
20-40-4	8-1-B	15	150	400	45
20-40-5	8-1-F	15	150	400	45
20-5	8-2-M	15	200	650	30
30-2	8-01	7	70	150	12
30-2+	8-01	7	70	150	12
30-20	8-01	7	70	150	12
30-20+	8-01	7	70	150	12
30-2-3	8-01	7	70	150	12
30-20-3	8-01	7	70	150	12
30-3	8-02	10	100	250	15
30-3+	8-02	10	100	250	15
30-3-3	8-02	10	100	250	15
30-3-4	8-02	10	100	250	15
30-3-5	8-02	10	100	250	15
30-3-5	8-02	10	100	250	15

## 2- and 3-jaw puller with hydraulic spindle



20-2	8-01	7,0 to / 70 kN	12 Nm
20-2+	8-01	7,0 to / 70 kN	12 Nm
20-20	8-01	7,0 to / 70 kN	12 Nm
20-20+	8-01	7,0 to / 70 kN	12 Nm
20-2-3	8-01	7,0 to / 70 kN	12 Nm
20-20-3	8-01	7,0 to / 70 kN	12 Nm
20-3	8-02	8,5 to / 85 kN	14 Nm
20-3+	8-02	8,5 to / 85 kN	14 Nm
20-30	8-02	8,5 to / 85 kN	14 Nm



When using pullers with hydraulic spindles, the application of hydraulic pulling force must always be controlled, i.e., by the use of a torque wrench.

品番	含む	最大		最大 Nm
		t	kN	
20-2-B	8-01	7	70	12
20-20-B	8-01	7	70	12
20-3-B	8-02	10	100	15
20-30-B	8-02	10	100	15
20-4-B	8-1-B	15	150	45
20-40-B	8-1-B	15	150	45
20-2-3-B	8-01	7	70	12
20-20-3-B	8-01	7	70	12
20-3-3-B	8-02	10	100	15
20-3-4-B	8-02	10	100	15
20-3-5-B	8-02	10	100	15
20-30-3-B	8-02	10	100	15
20-30-4-B	8-02	10	100	15
20-30-5-B	8-02	10	100	15
20-4-3-B	8-1-B	15	150	45
20-4-4-B	8-1-B	15	150	45
20-4-5-B	8-1-B	15	150	45
20-40-4-B	8-1-B	15	150	45
20-40-5-B	8-1-B	15	150	45
20-2+B	8-01	7	70	12
20-20+B	8-01	7	70	12
20-3+B	8-02	10	100	15
20-30+B	8-02	10	100	15
30-2-B	8-01	7	70	12
30-20-B	8-01	7	70	12
30-3-B	8-02	10	100	15
30-2-3-B	8-01	7	70	12
30-20-3-B	8-01	7	70	12
30-3-3-B	8-02	10	100	15
30-3-4-B	8-02	10	100	15
30-3-5-B	8-02	10	100	15
30-2+B	8-01	7	70	12
30-20+B	8-01	7	70	12
30-3+B	8-02	10	100	15

EXTERNAL

EXTERNAL

## Selection of the right internal puller type

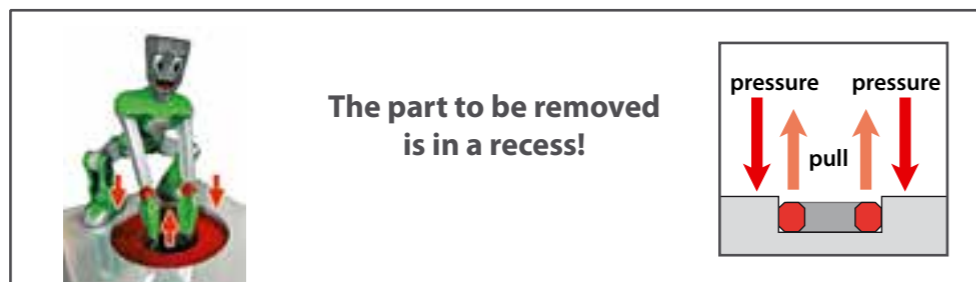

### 1st step: What is the interior diameter of the ball bearing

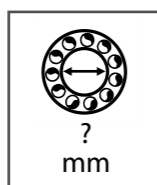

### 2nd step: Selection of the internal puller

<b>2 a</b> 2- and 3-shell Internal extractors  5-200 mm	<b>2 b</b> Segmented internal extractors for small spaces  5-78 mm	<b>2 c</b> Needle bearing extractors  9,6-25 mm
--	---	---

### 3rd step: What is access like?

<b>3 a</b> Supporting surface present → Counter stay 	<b>3 b</b> NO supporting surface present → slide hammer 
---	--

### Combinations of internal pullers with counter stays and slide hammers

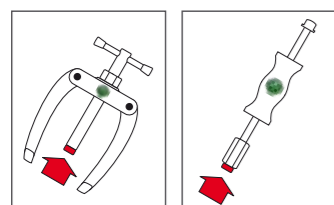

Counter stays and slide hammers can be combined with internal extractors of various sizes. The appropriate thread adapters are delivered with orders for counter stays and slide hammers. See also pages: 26-27

### How it works

For pulling internal ball bearings, ball bearing outer rings and bushings. The bearings are securely grasped by the internal puller, in the inner ring, and quickly removed using the clamping effect. In order to be able to remove a bearing with an internal puller, a counter support or a slide hammer from series 22 will always be required.

### Accessories: Extensions

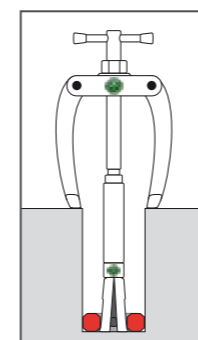

Many of the KUKKO internal extractors in the 21 series (not 21-E) can be expanded using an extension (series 21-V) for extracting parts set deep inside a bushing.

### Accessories: Thread adapters

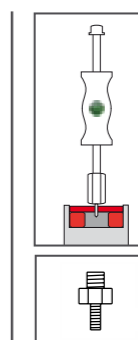

The KUKKO slide hammers can be used in combination with the thread adapters 22-1-AS anywhere where the threaded pin can be screwed directly into the part that needs to be removed.

### Safety instructions for internal pulling

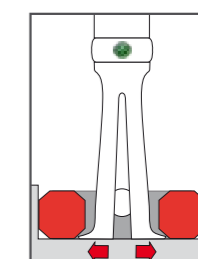
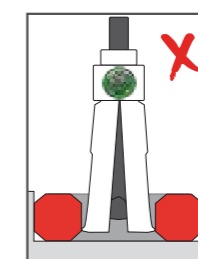
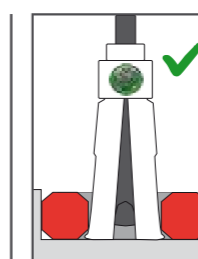
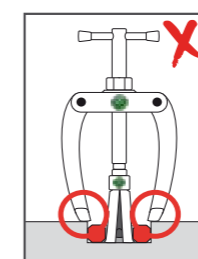
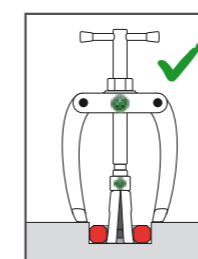

When using a counter stay, ensure that the jaws of the counter stay do not block the part being removed.

Note: the internal extractors must grip firmly underneath the part to be removed.

The internal extractor with segment tension allows extraction of horizontal components.

### Reversible jaws allow for both external and internal extractions.

#### Series 20 and 30



The external pullers can also be used as internal extractors by turning the jaws. *Important: When used as internal extractors, a fixed center point is required to brace the pressure screw of the products in these series.*

#### Serie 486-1



This puller can be used for internal and external extraction by replacing the pulling jaws. *The puller is designed to be used with a counter-stay, when a shaft is present or with a slide hammer, when no shaft is present.*



## Combination of counter stay with internal extractors, series 21

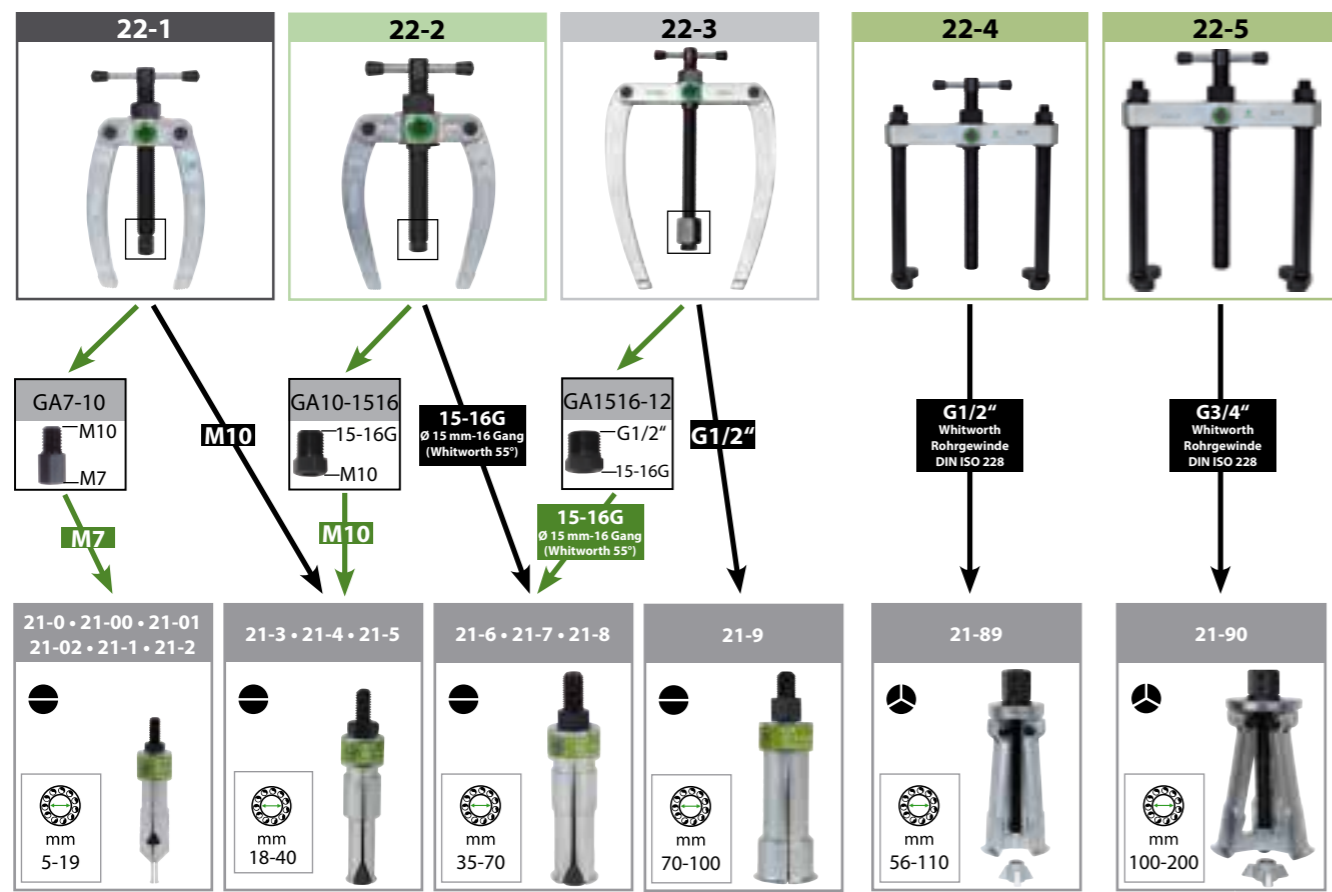

## Combination of counter stay with segmented internal extractors, series 21-E

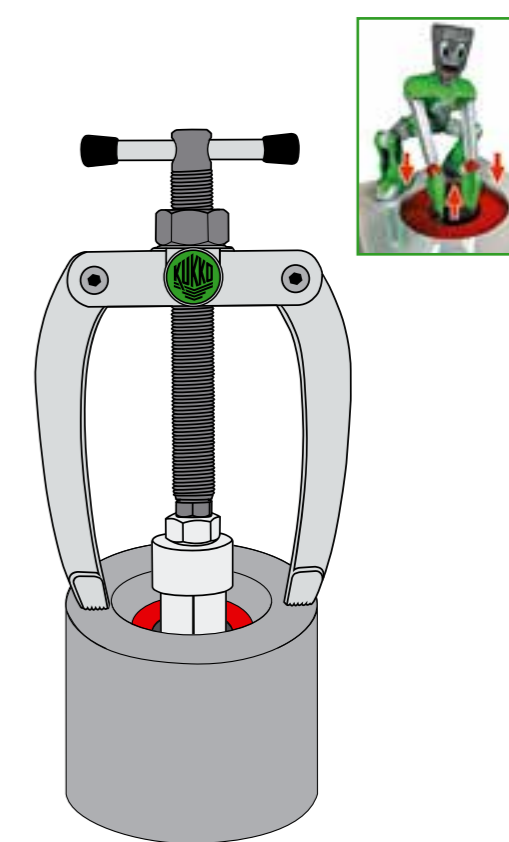
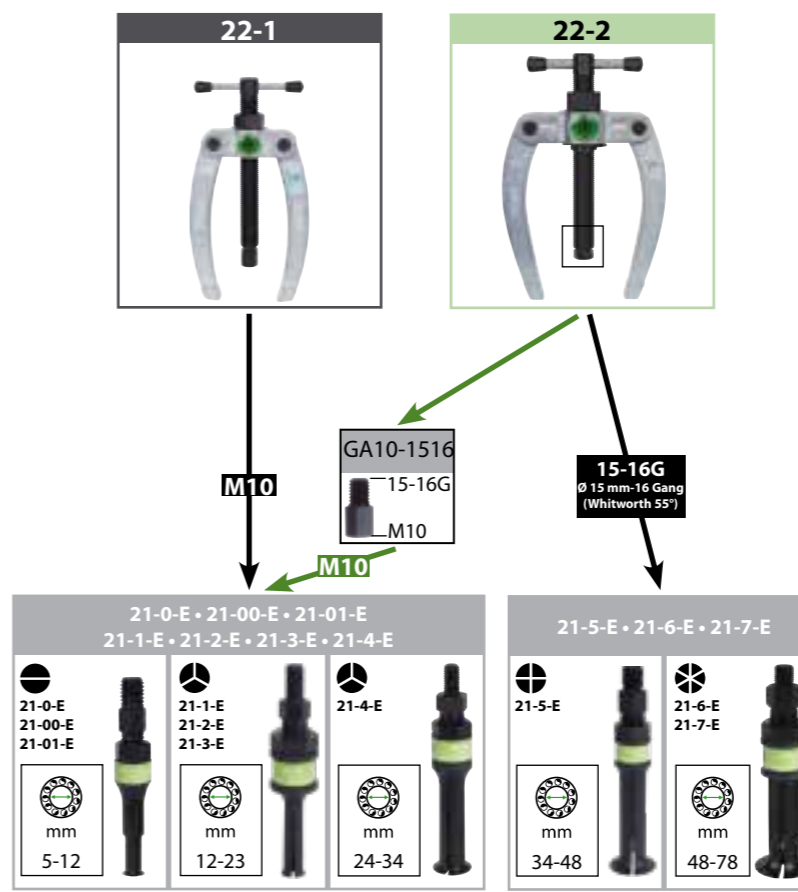

INTERNAL

INTERNAL

## Combination of slide hammer with internal extractors, series 21

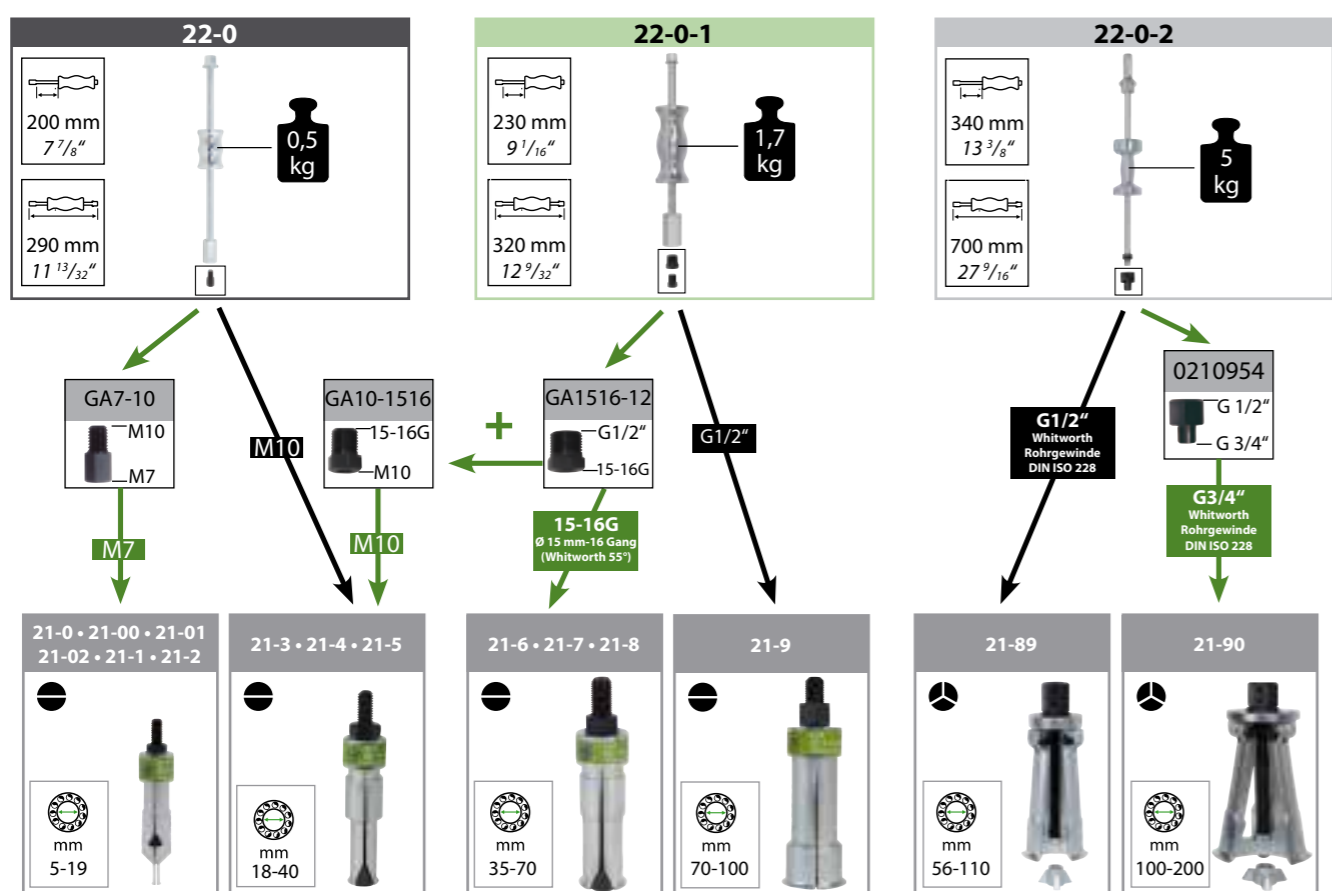

## Combination of slide hammer with segmented internal extractors, series 21-E

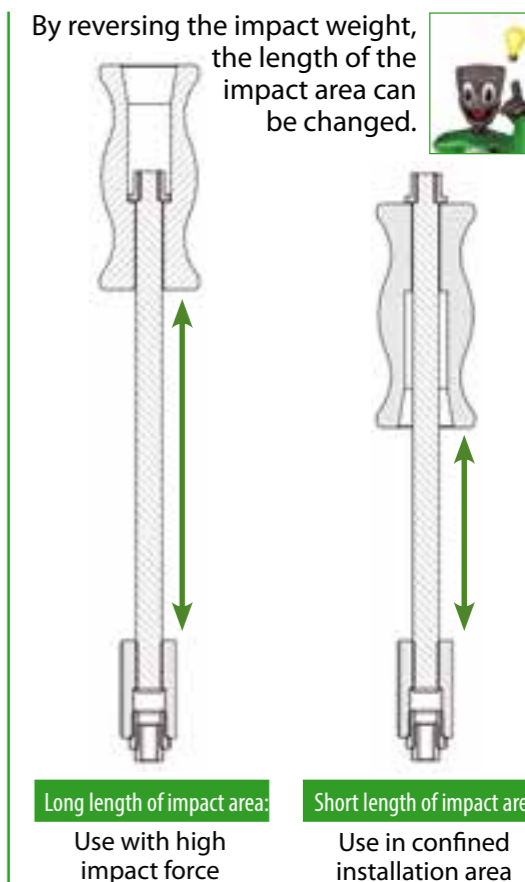
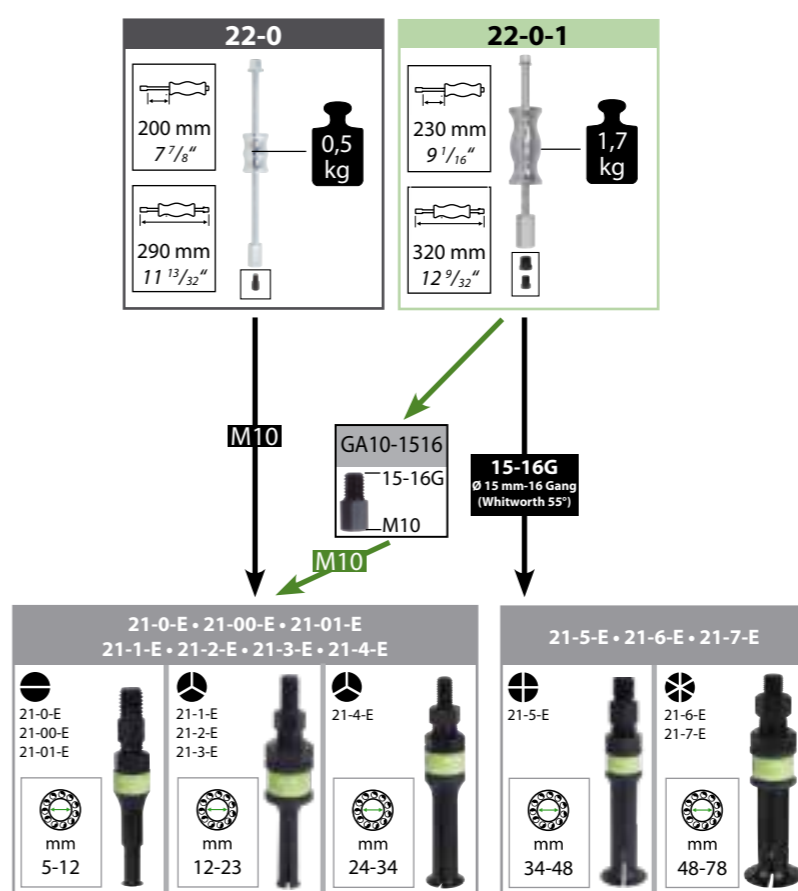

## Selection of the right separator



The part to be removed is level. It is not possible to use standard puller jaws!

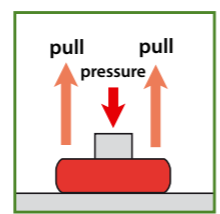

### 1st step: What is the diameter of the shaft?

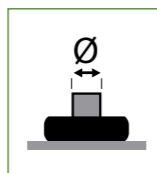

### 2nd step: Choice of the separator blade

2 (a) Separator series 15

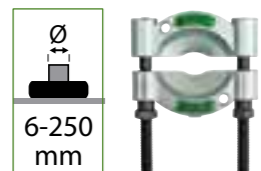

6-250 mm

2 (b) Separator with quick clamping pressure spindle, series 17

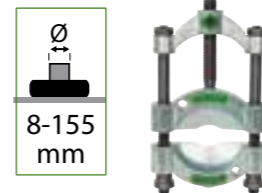

8-155 mm

**TIP:**  
One-hand operation due to quick-tension spindle

### 3rd step: Choice of the pulling device

3 pulling device series 18

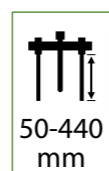

50-440 mm



### 4th step: Combination of the separating blade with the pulling device

4 (a) Separator



series 15  
+  
series 18

4 (b) Separator with quick clamping pressure spindle



series 17  
+  
series 18

## Mode of operation

For pulling tight parts such as ball bearings, roller bearings, inner rings and similar. The sharp, wedge-shaped blades are pressed behind the parts to be removed and, in this process, push between the bearing and the seat. For pulling, the tension bolts on the pulling device (series 18) must be screwed into the separator.

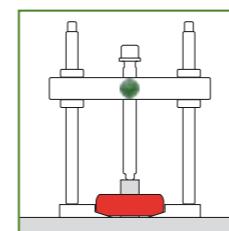

Normally, a separator blade is used in combination with a puller device.

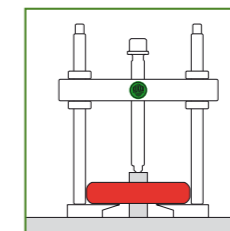

If the separating jaws are screwed into the pulling device the other way round, then pulling can be carried out flush and gently.

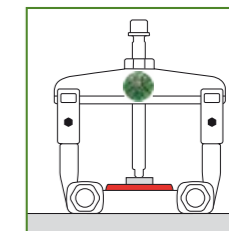

In some cases, an appropriate puller from the 20 series can be used instead of the puller bar.

## Accessories: Extensions

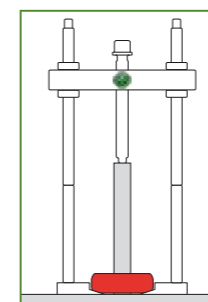

It is also possible to extend the puller bar for jobs involving longer shafts.

## Accessories: long hydraulic spindles

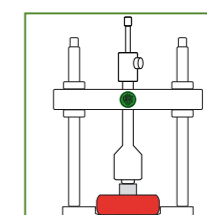

For particularly secure parts, in the larger models (from 18-2), the mechanical pressure spindle can be swapped for a hydraulic pressure spindle.

## More Separators

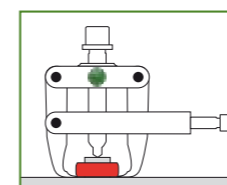

The extensive KUKKO line also supplies separators with side clamps, such as the 204 and 210 Cobra series.

## Safety instructions for separating

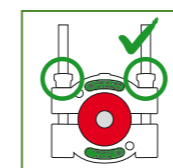

The adjusting nuts on the separator must be tightened in alternating and equal turns. Otherwise, the separator blade may tilt on the bolt or the thread may be damaged.

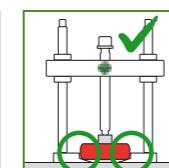

When pulling the separator blade, ensure that before the pulling device is pulled upwards the blade is firmly seated up to the stop under the part to be removed.

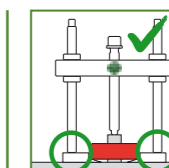
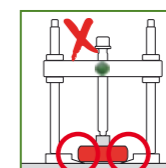

The side bolts of the pulling device must always be spindled into the separator blade until they stop.

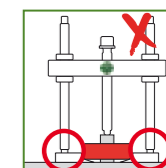

## Selection of the right ball bearing extractor

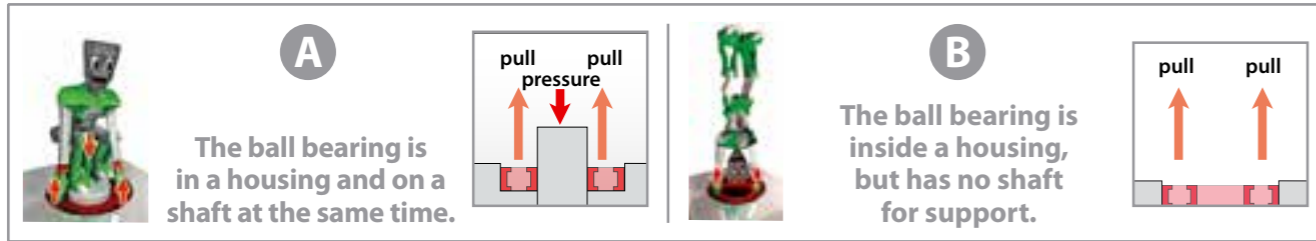

### 1st step: What is the ISO number of the ball bearing?

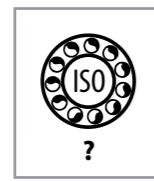

### 2nd step: Reusing of the ball bearing



### 3rd step: Choice of the right ball bearing puller

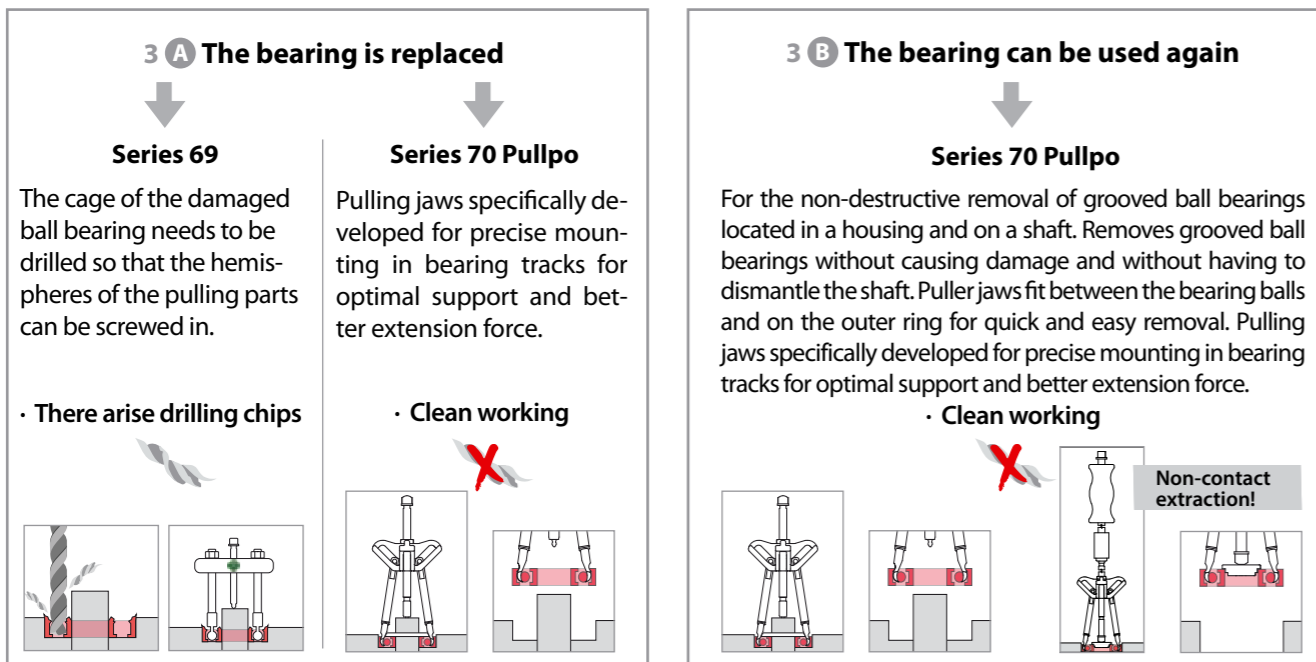

**TIP!** For unusually tight-fitting ball bearings on a shaft, we recommend the use of our inductive ball bearing heater, T-AW.

## BALL BEARING removal

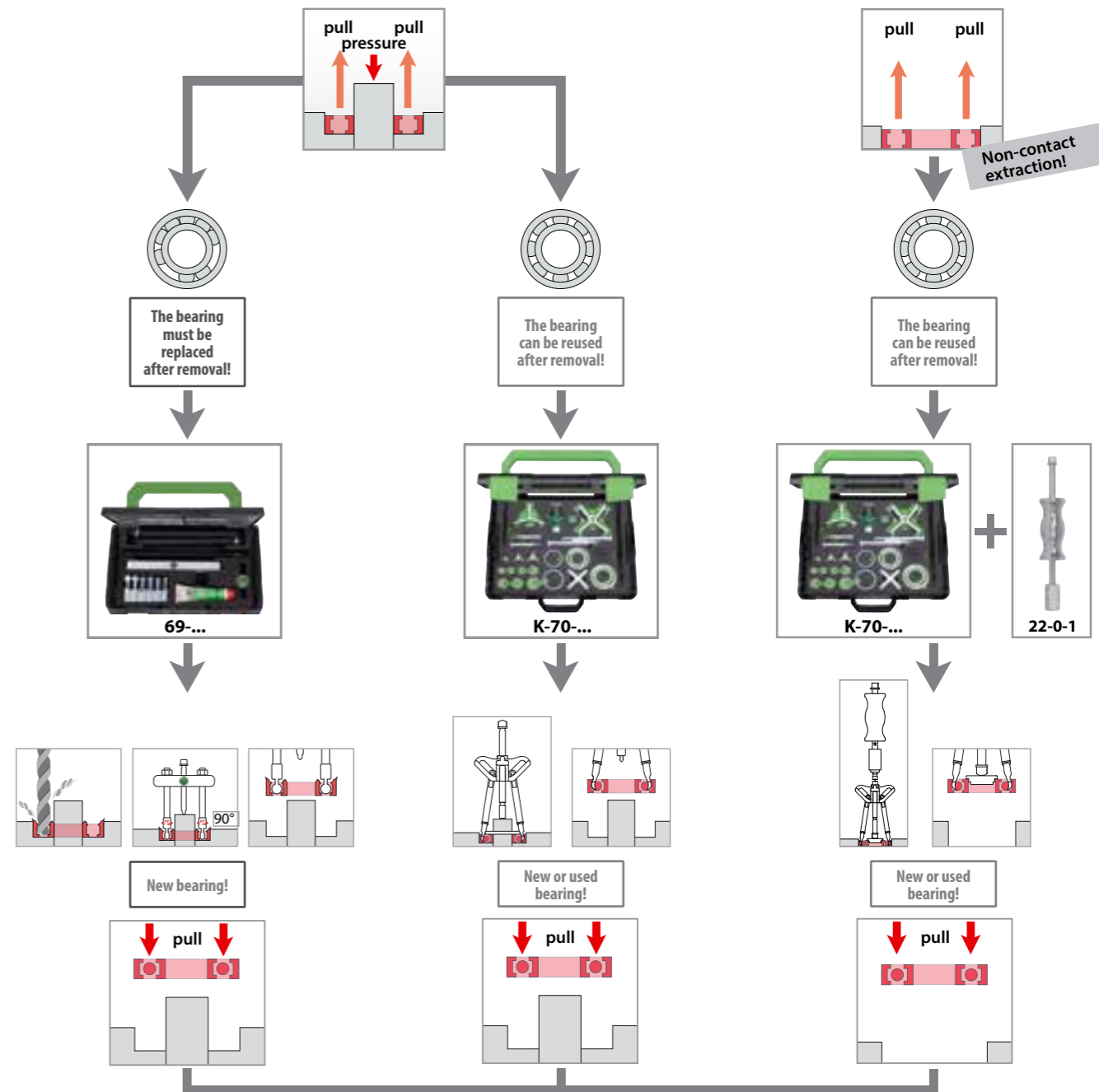

## BALL BEARING installation

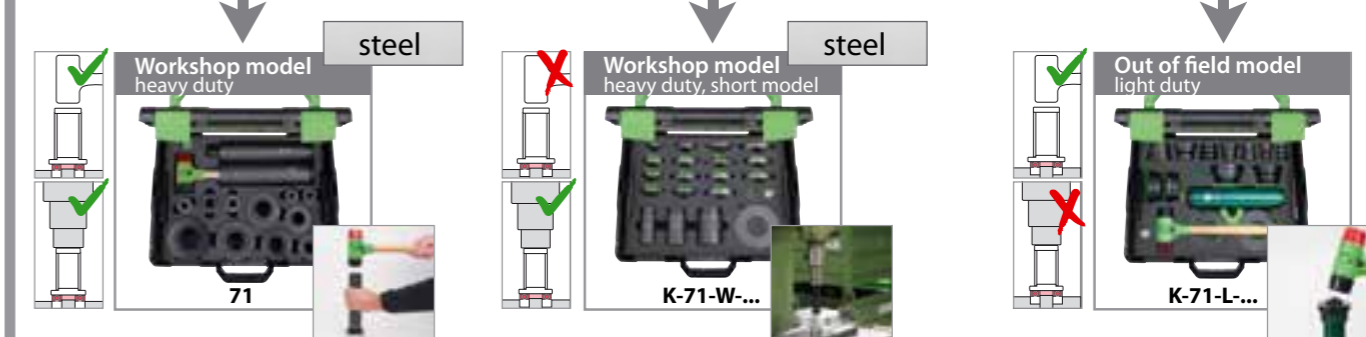

BALL BEARING

BALL BEARING



The KUKKO 800 modular system is a pull-apart system, which consists of single parts that can be put together individually from finished pullers or complete sets.

**ONE for ALL**

All pullers have the same hydraulic spindle and consist of easily exchangeable single parts that can be combined in many different ways.

**High pull-off force**

The short KUKKO hydraulic spindle means that little manual effort is required for maximum pulling performance. No additional drive tools are needed.

**Versatility**

The modular system allows for a large number of different pulling options.

**Selection of the right puller series 800**

**EXTERNAL**

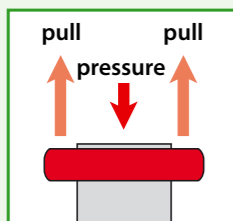

**INTERNAL**

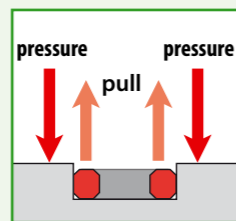

**SEPARATING**

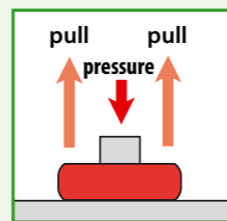

**1st step: Measuring the space available**

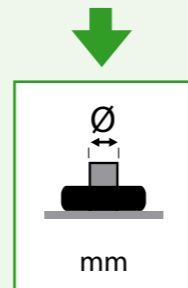
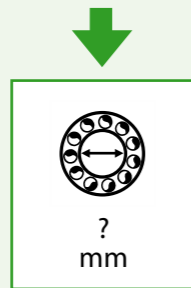
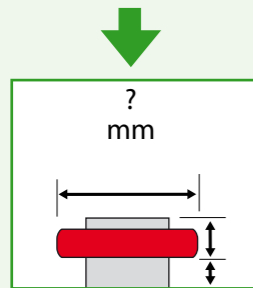

**2nd step: Selection of the puller type**

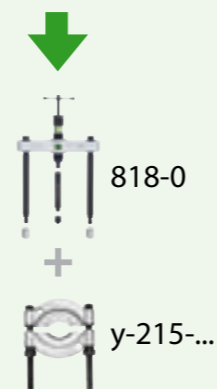
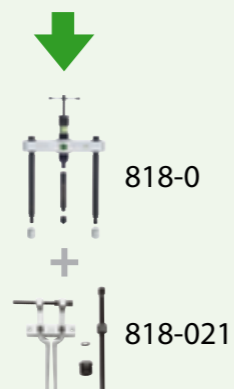
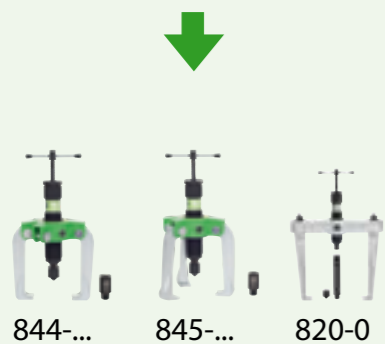

Simple operation of the hydraulic spindle with a T-handle.

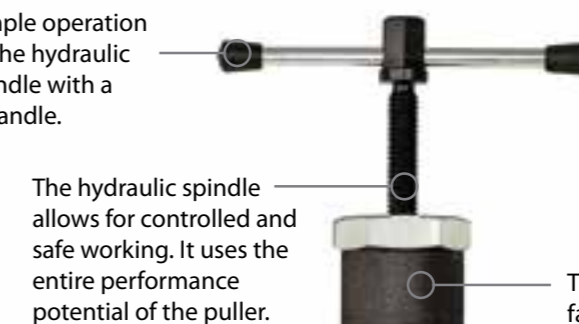

The hydraulic spindle allows for controlled and safe working. It uses the entire performance potential of the puller.

The grooved handle facilitates adjustment when applied to the workpiece.

The spindle nut has a groove that grabs the noses of the puller hooks. The puller pressure deployed pushes the nut deeper into the cross-beam, thereby tightening the puller hooks onto the part being pulled out.



The stable cross-beam enables fast replacement of the various puller hooks.

The fine threads of the hydraulic spindle allow for exact adjustment.

Additional spindle extensions are available in 3 different lengths.

The powerful puller hooks are made of grade tool steel.

With increasing spindle pressure, the puller hooks clasp the part being pulled out with automatically increasing force.

The part to be pulled lies only on the large support surfaces of the puller hooks and is pulled off gently.

**Assembly of the hydraulic puller**



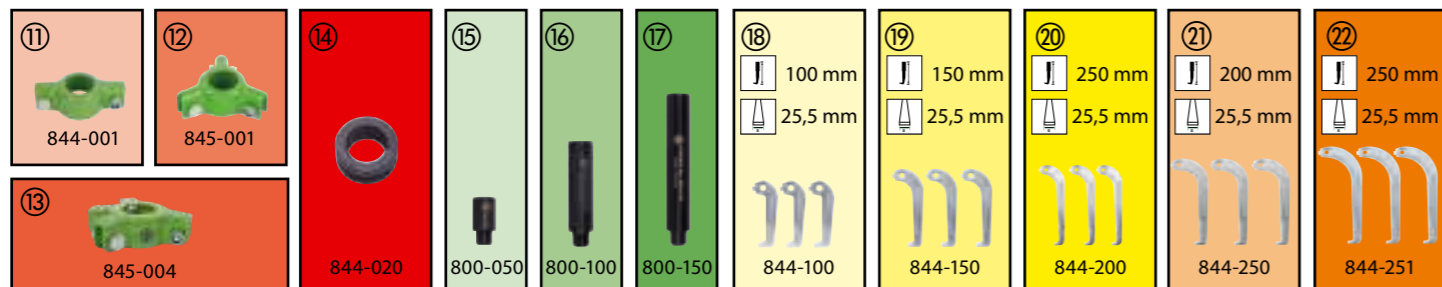
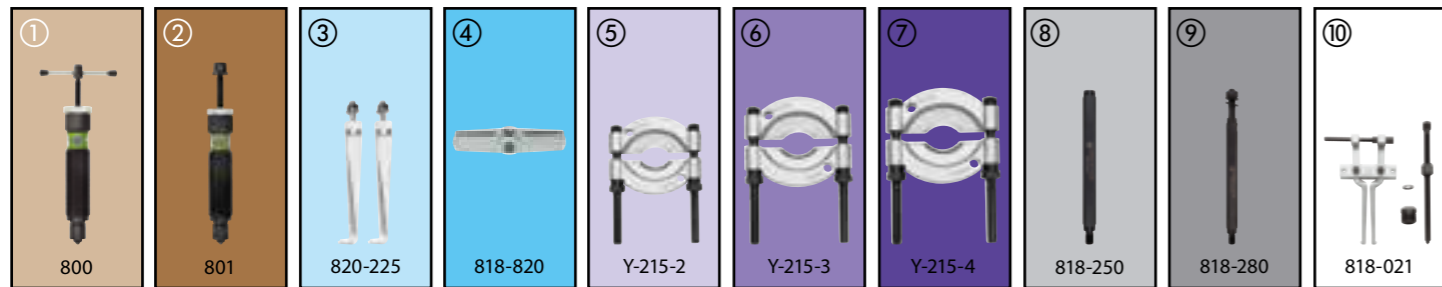

## COMBINATION

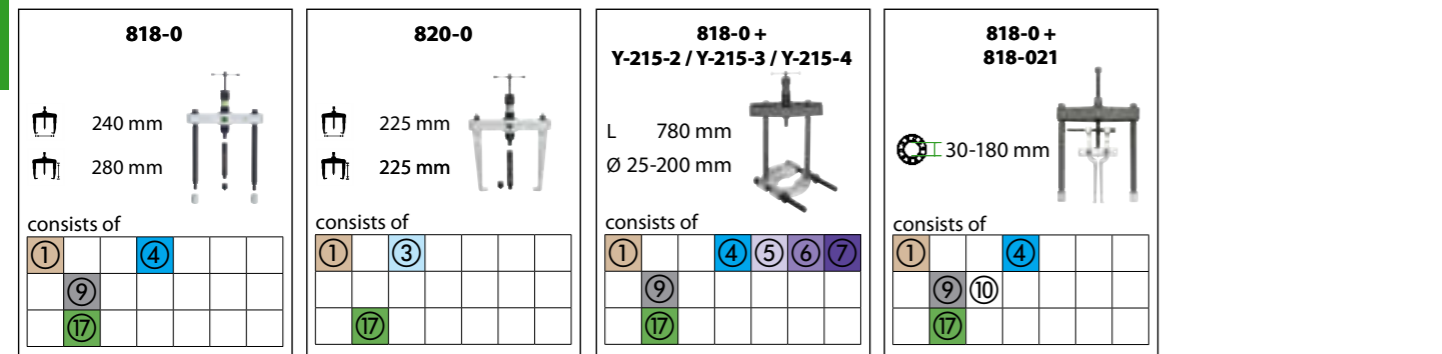
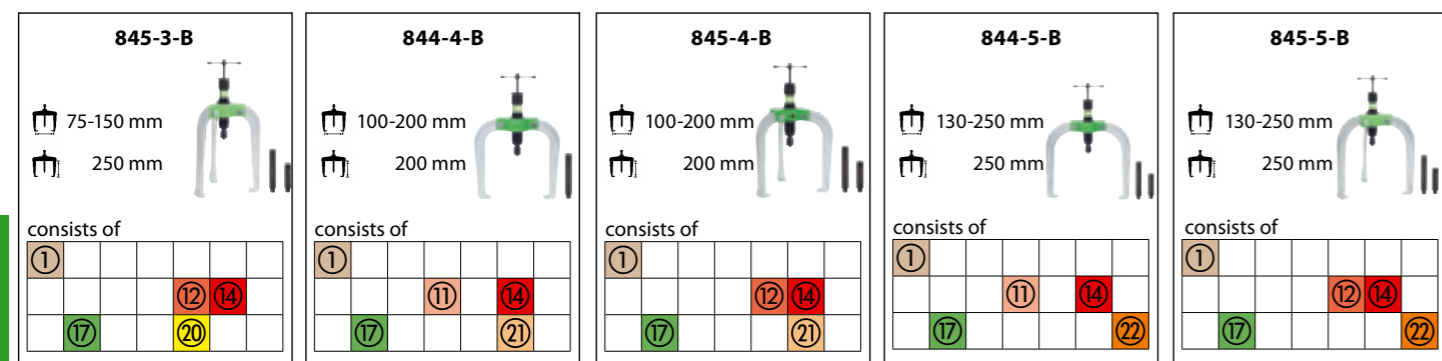
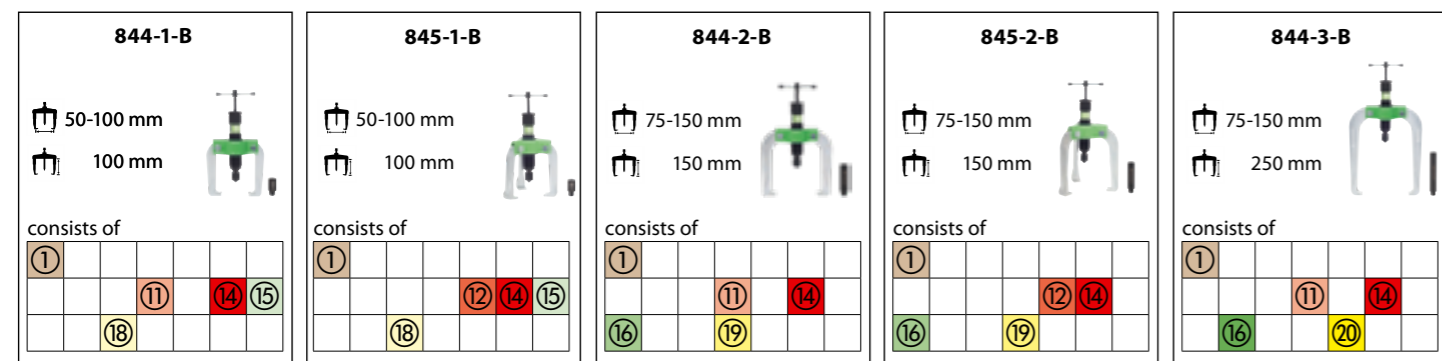

**Art.-No. 818-100**  
 L 530 mm  
 Ø 22-115 mm

set content: 10 parts

1		4	5	
8	9			15
16	17			

818-0 + Y-215-2

**Art.-No. 818-150**  
 L 780 mm  
 Ø 25-155 mm

set content: 12 parts

1		4	6	
8	9			15
16	17			

818-0 + Y-215-3

**Art.-No. 818-215**  
 L 780 mm  
 Ø 22-155 mm  
 ⌋ 225 mm  
 ⌋ 225 mm

set content: 16 parts

1	3	4	5	6	
8	9	10			15
16	17				

818-0 + Y-215-2; Y-215-3    818-0 + 818-021    820-0

**Art.-No. 845-150**  
 ⌋ 50-150 mm  
 ⌋ 100-150 mm

set content: 11 parts

1					
			13	14	15
16		18	19		

844-1-B, 844-2-B    845-1-B, 845-2-B

**Art.-No. 845-250**  
 ⌋ 75-250 mm  
 ⌋ 250 mm

set content: 15 parts

1					
			13	14	15
16	17		20	21	22

844-3-B, 844-4-B, 844-5-B    845-3-B, 845-4-B, 845-5-B

**Art.-No. 845-851**  
 ⌋ 75-250 mm  
 ⌋ 100-250 mm

set content: 21 parts

1						
			13	14	15	
16	17	18	19	20	21	22

844-1-B, 844-2-B, 844-3-B, 844-4-B, 844-5-B    845-1-B, 845-2-B, 845-3-B, 845-4-B, 845-5-B

**Art.-No. 845-855**  
 L 780 mm  
 Ø 25-155 mm  
 ⌋ 50-250 mm  
 ⌋ 100-250 mm

set content: 29 parts

1		4	6			
8	9	11	13	14	15	
16	17	18	19	20	21	22

844-1-B, 844-2-B, 844-3-B, 844-4-B, 844-5-B    845-1-B, 845-2-B, 845-3-B, 845-4-B, 845-5-B    818-0 + Y-215-3

**Art.-No. 845-858**  
 L 780 mm  
 Ø 25-155 mm  
 ⌋ 50-250 mm  
 ⌋ 100-250 mm  
 ⦶ 30-180 mm

set content: 30 parts

1		4	6			
8	9	10	11	13	14	15
16	17	18	19	20	21	22

844-1-B, 844-2-B, 844-3-B, 844-4-B, 844-5-B    845-1-B, 845-2-B, 845-3-B, 845-4-B, 845-5-B    818-0 + Y-215-3    818-0 + 818-021

## Choice of the correct ball joint extractor

### 1st step: What is the installation situation?

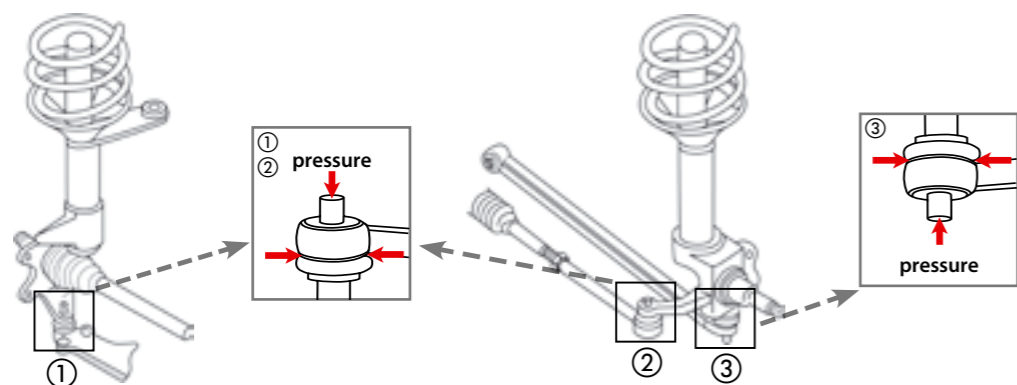

### 2nd step: How big is the ball joint?

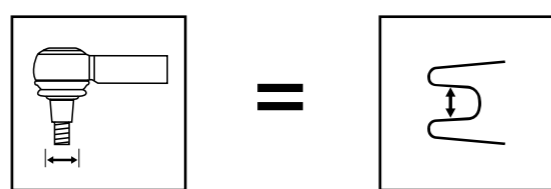

### 3rd step: Choice of the ball joint extractor type

#### Series 135

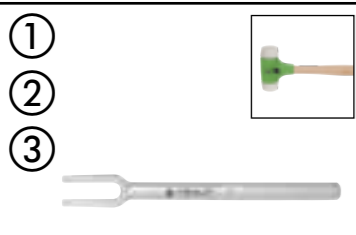

$\varnothing$  18-45 mm

- Simple, economical method
- For tight spaces
- Hammer required
- Possibility of damage to the rubber cuff

#### Series 128

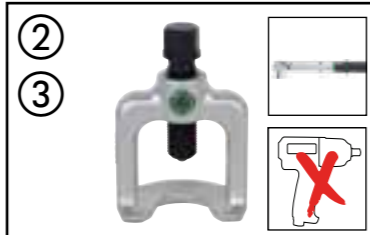

$\varnothing$  18-50 mm

- Bell-shaped design
- Direct pressure on the ball pin
- Ideal if enough space is available
- Working without damage
- A torque wrench is recommended for the drive

#### Series 129

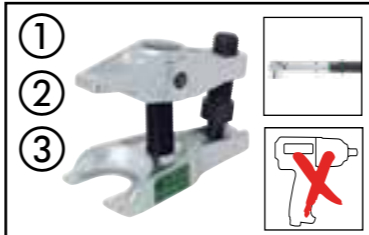

$\varnothing$  18-50 mm

- Leverage
- Very forceful
- Work area is shifted outside
- Ideal in tight spaces
- Hydraulic variants for very high power requirements
- Working without damage
- A torque wrench is recommended for the drive

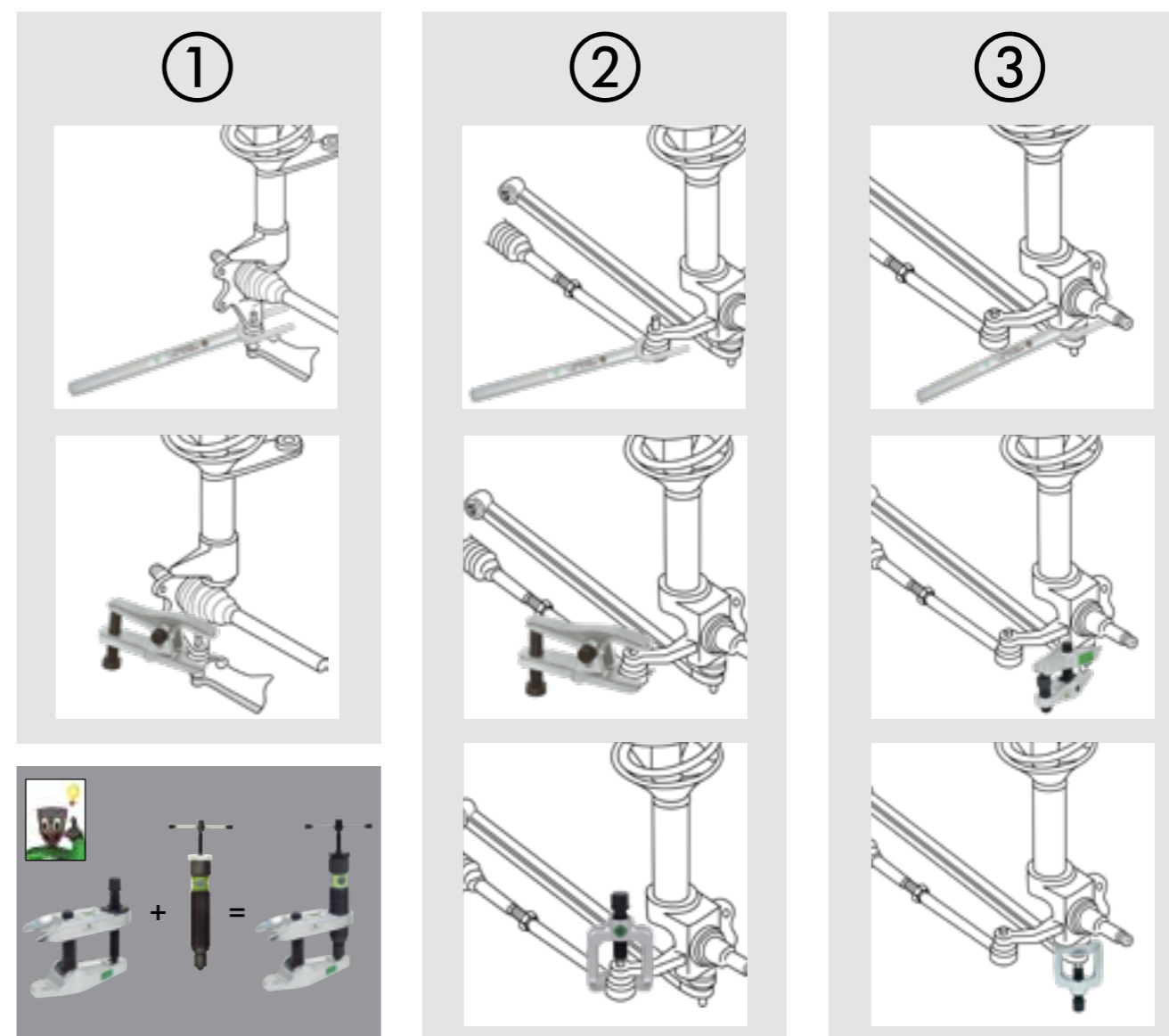
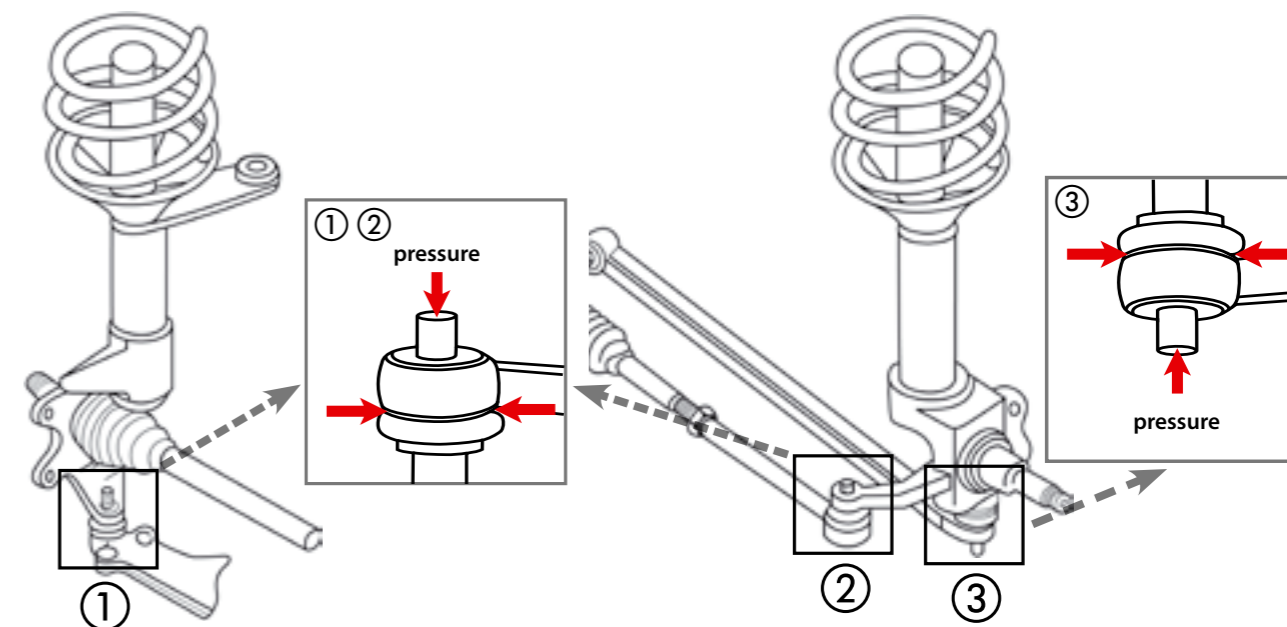



## Workshop tool trolley, K-CubeBoxx

that can be combined with drawers for the proven KUKKO L-BOXX system.



The new KUKKO workshop car system is an ideal complement to the traditional wall panel. The stability of the trolley is due to the base frame. Additional advantages include its mobile use for repairs directly on the vehicle or using it for orderly, central storage of pulling tools in the operation. The system can be individually combined with Sortimo boxes from the KUKKO product range or from other manufacturers.



### Description:

- Tilt-resistant with stable design.
- Smooth and stable load castors, including two with brakes.
- Simple loading of extracts with KUKKO-L-Boxx cases.
- Fully assembled prior to delivery, including black rubber mat in the storage compartment.

### Advantage:

- Ideal work height for use in workshops and industry.
- Smooth-running extracts and self-closing mechanism for the drawers.
- KUKKO L-BOXX - quickly and easily adjustable with quick locking mechanism.
- Simply remove the drawers to use the large L-BOXX separately.



KUKKO L-Boxxen **not** included.

## EXTERNAL pulling



## INTERNAL pulling



## SEPARATING



## BALL BEARING removal and installation





GENERAL

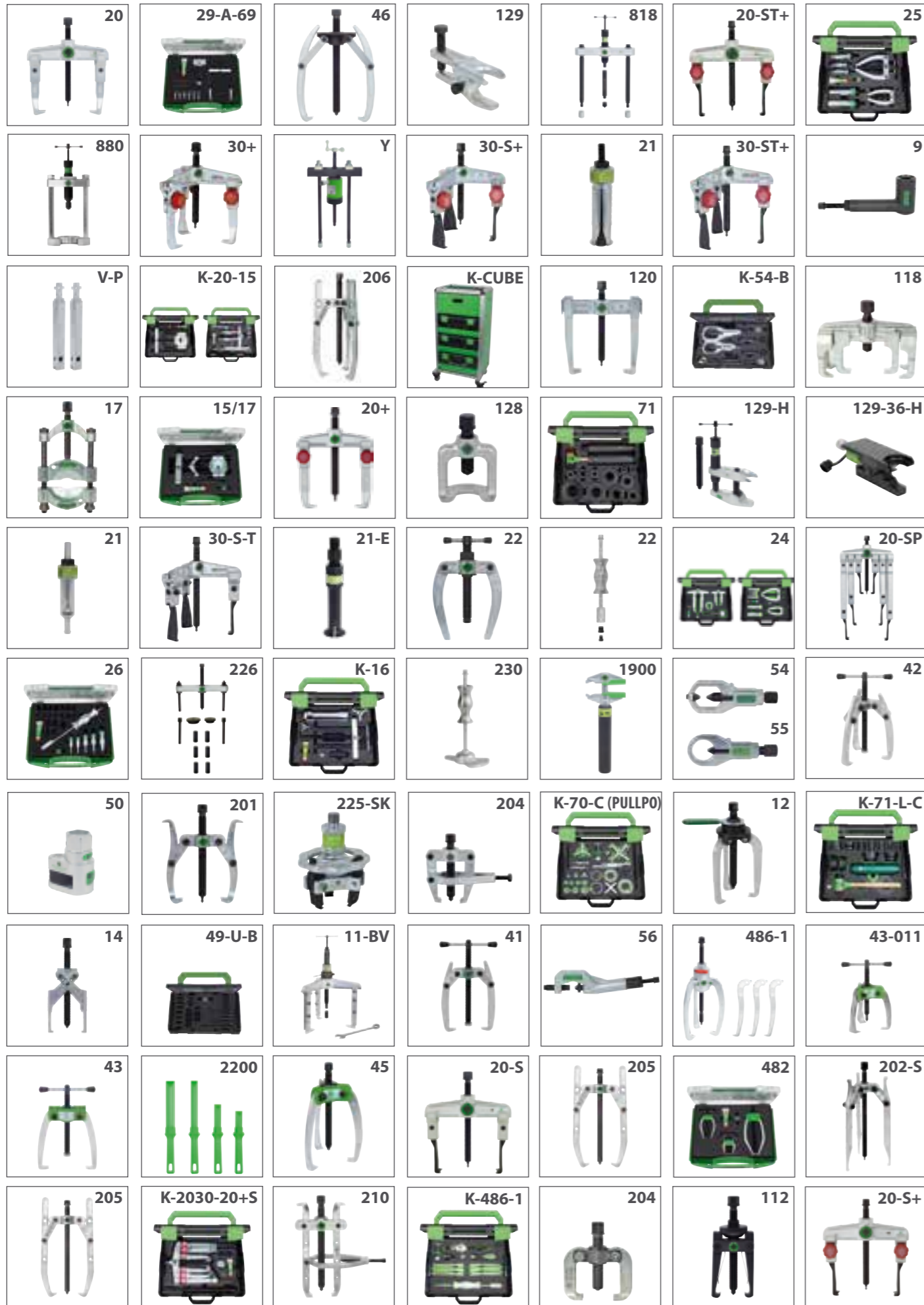

GENERAL



	<p>The geometry of the cross-beam and sliding parts has been optimized to ensure particularly easy movement of the extractor jaws along the cross-beam.</p>	
	<p>A manual adjustment knurl allows rapid loosening and adjusting of the extractor jaws on the cross-beam without using a wrench.</p>	
	<p>The cross-hooks guarantee maximum stability due to the mounting of the puller jaws in the sliding part.</p>	
	<p>The operating nut is easy to turn thanks to a built in pressure bearing. Resistance from friction is reduced to a minimum.</p>	
	<p>Smooth-running, self-adjusting spring-back jaws.</p>	
	<p>Automatic tensioning and centering of the extractor jaws.</p>	
	<p>By turning the locking bolt the jaws are centered and tensioned and therefore firmly grip the piece to be pulled off. This prevents the jaws moving or slipping off.</p>	
	<p>Optimal adjustment of the spindle to the shaft with 2-sided spindle tip (ball and tip).</p>	
	<p>Unique, simple pullback of the nut splitter chisel to remove it from deformed or split nuts. The chisel does not get stuck in the nut.</p>	
	<p>Tools with hydraulic function.</p>	

<h2>Precautionary Notes and Helpful Hints</h2> <p>All tools must always be used for the intended purposes under the envisioned conditions and within their postulated limitations.</p>		
	<p>Check the condition of your tools at regular intervals, and replace any damaged or worn parts.</p>	
	<p>Keep the threads of all pressure spindle and cross-beam clean and well oiled. (KUKKO special sliding grease for pressure spindle Art. 699999)</p>	
	<p>Before you start work, acquaint yourself with the proper use of the tool or tools in question, with due attention to pertinent safety measures.</p>	
	<p>If anything at all is unclear about any of the above, it is best to call the factory for some firsthand advice.</p>	
	<p>Prior to starting work, make sure that the pulling tool is in good working order.</p>	
	<p>Double-check the tool for correct mounting, and monitor the forces incidental to the pulling process.</p>	
	<p>Never violate the maximum load data prescribed for the tool in question. Use a torque wrench (for mechanical/pressure-screw-driven tools) or a pressure gauge (hydraulic/pump-driven tools) to keep tabs on the applied forces.</p>	
	<p>Always wear suitable personal protective equipment, including protective goggles.</p>	
	<p>Always wrap the pulling tool and the workpiece in a protective blanket as a precaution against the potential effects of sudden release.</p>	
	<p>If the tool appears to be overloaded, works sluggishly, or is otherwise negatively conspicuous, interrupt the pulling process, and replace the tool with a larger model.</p>	
	<p>Never use an electric- or pneumatic-powered impact/hammer drill for driving a pulling tool.</p>	
	<p>Never use extensions to increase the applied torque.</p>	
	<p>Never alter a pulling tool or related product in any way.</p>	
	<p>Since heat detracts from the thermal properties of steel, and since some parts require heating to facilitate their removal, remember to never heat the pulling tool along with the part.</p>	



Мы приводим в движение мир Een wereld ron  
ilman liikkeessä Un mundo en movimiento  
n i b... lse En verden i bevægelse



en movimento Мы приводим в движение  
aailman liikkeessä En verden i bevægelse  
world in motion En verden i bevægelse  
ine Welt in Bewegung  
onde en mouvement Мы приводим в движение  
orld in motion En verden i bevægelse  
rondom beweging Un mondo in movimento  
Un mondo in movimento En värld i rörelse  
Мы приводим в движение мир 让世界转动起来

ilman liikkeessä Un mundo en movimiento  
n i bevægelse En verden i bevægelse  
und... movimento En verden i bevægelse  
En ve... bevægelse En värld i rörelse  
年... 統と最新技術...  
Sw... rucht... It i...  
30... 10...



**KUKKO-Werkzeugfabrik**  
Kleinbongartz & Kaiser oHG  
Heinrich-Hertz-Str. 5 · 40721 Hilden · GERMANY  
Phone: +49 2103 9754-300 · Fax: +49 2103 9754-310  
[info@kukko.com](mailto:info@kukko.com) · [www.kukko.com](http://www.kukko.com)



**KUKKO on Facebook**  
[www.facebook.com/kukkotools](http://www.facebook.com/kukkotools)

